

# Microwave data link **AL80GE**

---

## Installation and operation manual



# Content

page.

|   |           |
|---|-----------|
| <b>1. INTRODUCTION</b> .....  | <b>1</b>  |
| 1.1 BASIC DATA.....   | 2         |
| <b>2. DESCRIPTION OF THE LINK</b> .....                                       | <b>4</b>  |
| 2.1 TX POWER REGULATION .....   | 7         |
| 2.2 THE PROTECTED TERMINAL BOX ALSx .....                                     | 8         |
| 2.2.1 <i>Input Connectors</i> .....   | 10        |
| 2.2.2 <i>Output Connectors</i> .....  | 11        |
| 2.2.3 <i>Indikace</i> .....   | 12        |
| 2.2.4 <i>Cables in KRONE cutting boxes</i> .....                              | 13        |
| 2.3 OUTDOOR UNIT (ODU) .....  | 14        |
| <b>3. INSTALLATION INSTRUCTIONS</b> .....                                     | <b>20</b> |
| 3.1 STATION INSTALLATION .....  | 20        |
| 3.2 EVALUATION OF SUITABLE PLACEMENT.....                                     | 20        |
| 3.3 PLACEMENT OF THE ANTENNA ON A SUPPORT CONSTRUCTION.....                   | 21        |
| 3.4 LOCAL FREQUENCY COORDINATION.....   | 23        |
| 3.5 INSTALLATION OF THE ANTENNA SYSTEMS.....                                  | 23        |
| 3.5.1 <i>UNI1-80RF (UNI2-80RF) antenna</i> .....                              | 24        |
| 3.6 GROUNDING .....   | 26        |
| 3.7 ATTACHMENT OF FEEDER TO THE ANTENNA .....                                 | 27        |
| 3.8 TYPICAL ODU WIRING .....  | 28        |
| 3.9 USER SPACE COVER HANDLING .....   | 29        |
| 3.10 INSTALLATION OF INTERCONNECT CABLE .....                                 | 30        |
| 3.11 SFP OPTIONAL MODULES .....   | 32        |
| 3.12 INSTALLATION OF OPTICAL CONNECTOR MOLEX 106059 .....                     | 33        |
| 3.12.1 <i>Package content</i> .....   | 33        |
| 3.12.2 <i>Optical cable preparation</i> .....                                 | 33        |
| 3.12.3 <i>Connector assembling</i> .....                                      | 33        |
| 3.13 BEFORE PUTTING THE RADIO LINK INTO OPERATION.....                        | 34        |
| 3.14 ACCESSORIES.....   | 34        |
| <b>4. SETTING OF THE RADIO LINK AND ITS COMMISSIONING</b> .....               | <b>36</b> |
| 4.1 POINTING OF RADIO RELAY LINK .....  | 37        |
| 4.2 CONTROL CALCULATION .....   | 42        |
| 4.3 DIRECT CONNECTION OF A MONITORING PC.....                                 | 43        |
| <b>5. OPERATION INSTRUCTIONS</b> .....  | <b>45</b> |
| 5.1 OPERATION.....  | 45        |
| 5.2 EMERGENCY CONDITIONS .....  | 46        |
| 5.3 REPAIRS .....   | 46        |
| 5.4 ENDING OF OPERATION – ECOLOGICAL LIQUIDATION.....                         | 46        |
| <b>6. SAFETY CHECK</b> .....  | <b>47</b> |
| <b>7. RADIO RELAY LINK PARAMETERS</b> .....                                   | <b>48</b> |
| 7.1 FREQUENCY PLAN 80GHz .....  | 48        |
| 7.2 MODULATION, THRESHOLD SENSITIVITY AND TRANSFER CAPACITY OF THE LINK ..... | 49        |
| 7.3 TECHNICAL PARAMETERS .....  | 49        |
| 7.4 ENVIRONMENT .....   | 50        |
| 7.5 ANTENNA SYSTEMS .....   | 51        |

- 8. MAIN EQUIPMENT DIMENSIONS..... 52**
  - 8.1 ODU – OUTDOOR UNIT ..... 52
  - 8.2 PROTECTED TERMINAL BOX ..... 52
  - 8.3 ODU WITH ANTENNA ..... 54
  
- 9. APPENDIXES ..... 55**
  - 9.1 LIST OF FIGURES ..... 55
  - 9.2 LIST OF TABLES ..... 55

## 1. INTRODUCTION

ALCOMA AL80GE is compact and easy to deploy Gigabit Ethernet radio relay link suitable for both last miles and shorter backbone links. Service availability is comparable to optical fiber. Typical link distance is 3 – 5 km for 99.99 % availability. AL80GE operates in 71–76 / 81–86 frequency band according to ECC recommendation (05)07. AL80GE supports both copper and optical fiber interfaces. The whole link is built into the outdoor unit. Indoor overvoltage protection terminal box with the grounding bolt is available.

The radio relay link AL80GE as a whole or as parts is not intended to be used by untrained personnel. Installation, adjustments and maintenance must be performed only by a person with electrical qualifications trained by the manufacturer.

Please read this operation manual carefully before installation and operation of the duplex microwave link for data transmission ALCOMA AL80GE. Please pay increased attention to the safety instructions that are marked like this in the text:



### WARNING

Violating of this marked safety instructions can cause serious injury to personnel.



### CAUTION

Violating of this marked instructions can cause damage to the equipment.



### TIME EXPIRATION

Link is time expired. Date of expiration is marked on ODU, in invoice and in dagnostic system ASD Client – menu Supervisor-Identification-Local/Remote station. Contact seles department of your supplier before expiration date and ask for unblocking software codes. Only diagnostic data are transfered after expiration date.

## 1.1 BASIC DATA

- Licensed frequency band 80 GHz (71-76 a 81-86 GHz)
- Point to Point type link
- The AL80GE link is designed as unattended
- The user data transmission capacity is 1 150 Mbit/s
- The total transmission capacity is 1 250 Mbit/s
- Channel bandwidth is 1.5 GHz
- Digital modulation DBPSK
- ATPC - automatic output regulation (ATPC lowers mutual interference of links and lowers operational costs)
- Advanced FEC - forward error correction
- Full duplex operation
- Vertical or horizontal polarization
- Interfaces: 2 Ethernet 100Base-TX channels marked as User line 2 and User line 3
- Optional SFP slot for Ethernet 1000Base-T/LX/SX/BX marked as User line 4.
- One or two independent user data channels are transmitted, diagnostic data can be optionally transmitted in any of those.
- The link consists of the outdoor ODU unit, protected terminal box ALS1-GEth or ALS1-2GEth and the appropriate cables
- The link can be supervised by the ASD Client program, through a web interface, hyperterminal, or SNMP protocol Ver. 1
- For the maintenance and diagnostic program ASD Client actual version see the following web page: [www.ALCOMA.com](http://www.ALCOMA.com)
- The radio relay link AL80GE enables using of the antenna types ALCOMA UNI1-80RF, UNI2-80RF
- ODU contains the acoustic signalization of incoming signal level RSSI
- ODU is sealed, **warranty is void if seal removed or broken**



### WARNING

The microwave link outdoor unit contains a microwave transmitter, which causes the health risk of non-ionizing radiation while in operation. It is dangerous to look directly into the antenna, or stay close in front of it, while the transmitter is in operation. The danger increases in direct proportion to the transmitted output. It is not allowed to switch on the transmitter without connected parabolic antenna. During work on and presence by the antenna, while the transmitter is in operation.

The radio relay station AL80GE consists of three main parts:

1. The outdoor microwave unit (ODU) that is integral with the antenna contains:
  - The RF block that includes the microwave transmitter, receiver, and filters. Regarding to TX frequency ODUs are made in two versions:
    - A for higher frequency range
    - B for lower frequency rangeRespective units make up duplex pair, e.g. A-B.
  - The data block that includes 1 Ethernet 1000 switch, a modem and the monitoring system supervised by a controller. The power supply block consists of DC-DC convertors.
2. The antenna system with the parabolic antenna, the feed element and the pole attachment.
3. Considering placement of the data block in ODU, the station AL80GE has an indoor unit reduced to the protected terminal box **ALS1-GEth (RP)** or **ALS1-2GEth (RP)** that ensures transmission of customer data, powering of the station, and protection against the atmospheric origin overvoltage and overcurrent. (The protected terminal box is marked as **ALS1x** in the further text.)

ODU can be connected to the microwave parabolic antennas ALCOMA UNI1-80RFx (Ø 0.35 m), UNI2-80RFx (Ø 0.65 m). These antennas are standard equipped by icing protection (radome) for use in demanding climatic conditions. The simply removable ODU is integrated with the antenna system into one compact whole.

Interconnection between the protected terminal box and ODU is done by a double shielded outside cable (S-STP Cat 7) with 4 pairs of conductors with the 100 Ω impedance. In case of using two metallic GEth interfaces two interconnecting cables must be used. **The LINE3 link cable transmits customer data and powering for ODU.** ODU monitoring signals may be transmitted by either LINE3 or LINE2 link cable.

Optical interconnecting cable must be chosen according to used SFP module type. It is recommended to use optical outside cable. SFP module used in ODU may be either 1000Base-LX Single mode (1310 nm) or 1000Base-SX multimode (850 nm) or 1000Base-BX singlemode (TX 1310 nm – RX 1550 nm) or 1000Base-BX singlemode (TX 1550 nm – RX 1310 nm). Disassembled optical connector is a standard accessory of SFP module equipped ODU. Customer may optionally order complete connectorized interconnection optical cable of appropriate length.

**CAUTION**

SFP module may be installed only to ODUs equipped with optical cable connector.

## 2. DESCRIPTION OF THE LINK

User data are connected to the protected terminal box ALS1x by the standard RJ45 connectors. The two-stage terminal protection limits breakdowns caused by overvoltage originating in atmospheric electricity, or due to industrial breakdowns. The protected terminal box contains user selectable jumpers enabling its optimum grounding and adjustment.

ODU is powered using the protected terminal box. The power supply in the range of +36 to +72 V, with the typical value of +48 V, is protected by the tube thermal fuse T2.0 A. The presence of supply voltage is indicated by a green LED. The supply voltage is transported to ODU by all four pairs of connecting cable conductors.



### CAUTION

Link AL80GE use only with protected terminal box marked

- **ALS1-GEth Line 3** (121/516\*35)
- **ALS1-2GEth** (121/516\*30)

protected terminal box **optimized for power backup**

- **ALS1-GEth RP** (121/516\*33)
- **ALS1-2GEth RP** (121/516\*34).

Protected terminal box optimized for **separate management**

- **ALS1-GEth + Line 2 NMS** (121/516\*38)

It is important to keep proper link of all connecting cable conductors both in ODU and ALS1x. There is danger of equipment damage in case that the links are not connected properly.

The main line power supply of the category SELV according to the EN 60950 "Information technology - Safety of information technology equipment ...".

The power cable ALS1x is connected by the connector that is screwed on the box of the protected terminal box, and so guarantees a reliable connection.

The protected terminal box is connected to ODU by a single shielded cable with 4 pairs of conductors. This cable is both on the side of the protected terminal box, and the ODU side connected by the "Krone" cutting boxes. The link cable passes through cable screw-in grommets on both sides, and so it is firmly attached to the box. The total length of the link cable and the cable that brings data into the protected terminal box can be max. 100 m long for the 100Mb/s Ethernet, for the Ethernet speed of 1000 Mb/s it can be max. 90 m long. These lengths are set and verified for the recommended cable S-STP Cat. 7. by ACOME. The terminal box ALSx is passive and the cable length must be considered from the terminal user device all the way to ODU.

The mechanical design of the protected terminal box assumes installation on TS35 DIN rail. The protected terminal box allows to bring the connection cable with ODU to the front panel. Customer data and the power supply can be brought to the front panel

Three protected terminal boxes ALS1x can be joined and installed into the 19" rack of 1U height. Joining profiles and rack mounting profiles must be added in that case.

The ODU input has similar overvoltage protection as the one in the protected terminal box, including a separate supply voltage. The supply voltage separated in the overvoltage protection is brought to the switch-on power supply. Activity of the ODU supply is indicated by the green LED placed on the mother board in the space of the user terminal area.

The high frequency block of the AL80GE link consists of a microwave receiver, transmitter, microwave oscillators and other support circuits.

Microwave oscillators generate signals for mixers in the receiver and transmitter. Its frequency is controlled by the PLL loop. Accuracy and stability of the frequency adjustment is determined by a crystal oscillator.

The intermediate frequency signal at the 12.75 GHz frequency from the modem is mixed with the signal from a microwave oscillator, filtered, and power amplified. The signal goes through a branch, where the transmitted output detection circuit resides. From there the transmitter signal goes through a diplexer to the transmitting antenna.

A received signal from the parabolic antenna is led through the diplexer to the receiver. There it is amplified and mixed to the intermediate frequency of 3.75 GHz and further amplified. From there the signal goes to a modem.

The demodulated signal goes from the modem to a muldex, where user data (Ethernet) are separated from the diagnostic data. The user data are sent to the protected terminal box again through the overvoltage protection by a connection cable with 4 pairs of conductors.

The voltage on the RSSI connector (figure 10) is proportionate to the intensity of the signal received from the opposite station. This voltage determines the height of the tone for the acoustic transformer that serves as an indicator during pointing of the link.

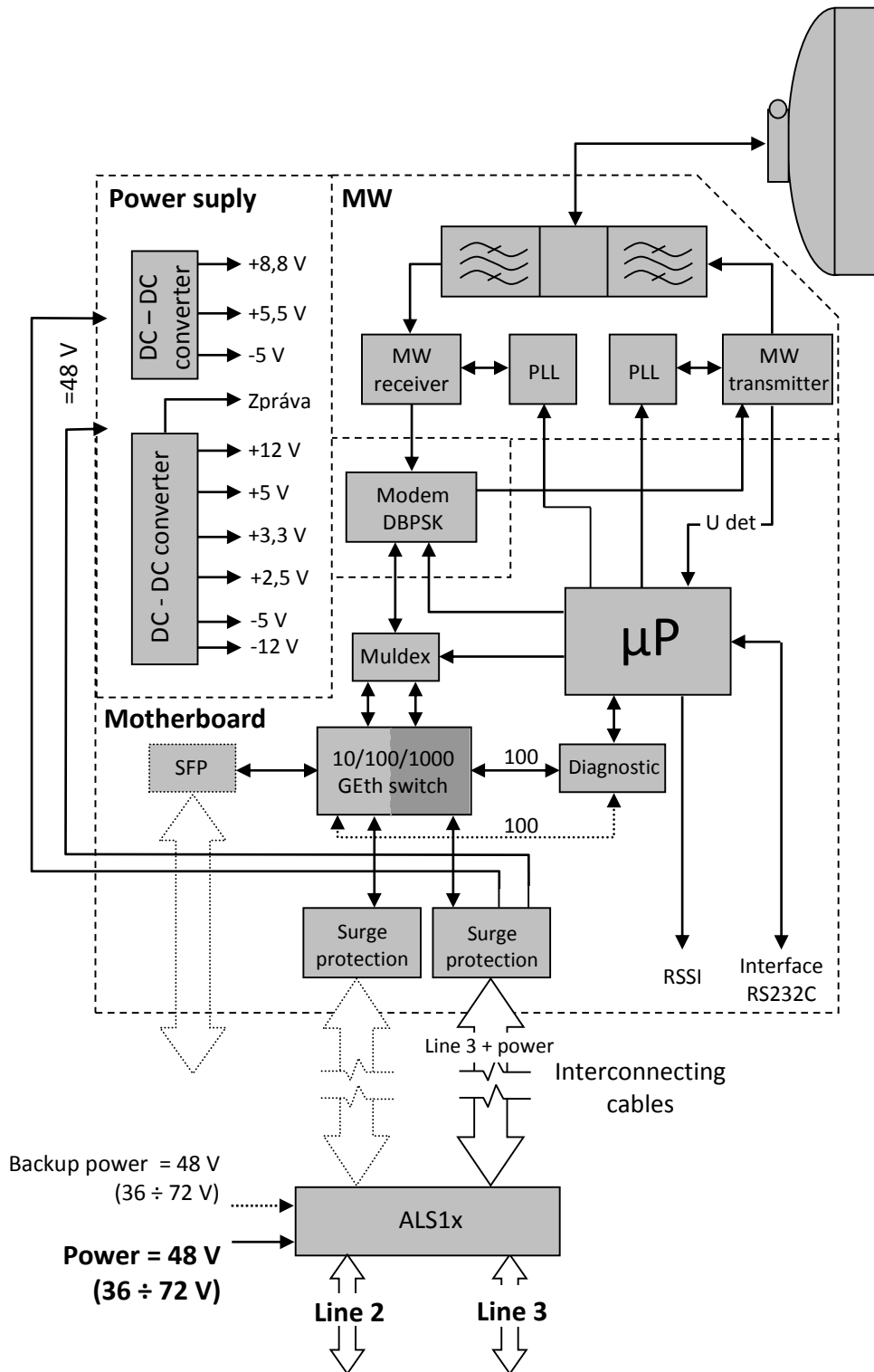

Figure 1 The block schematic of the AL80GE link

## 2.1 TX POWER REGULATION

The output power is set by manufacturer in conformity with maximum EIRP power conditions. EIRP calculates with both Transmitter output power and antenna gain. There are two different concepts of AL80GE link output power regulation concept:

1. The basic possibility is to set output power from maximum 20 dBm in steps of 1 dB and 20 dB range with keeping its time and temperature stability. It is possible to set the output power from the ASD diagnostic program. The power is regulated and displayed based on information from local transmitter. Microwave part of ODU is equipped with branch where transmitted output detection circuit with microwave diode resides. Detected value is used both for TX power regulation and displaying.
2. Advanced function of ATPC (automatic transmit power control) is based on regulation of output power according to the conditions of electromagnetic waves propagation. It decreases the output power during optimal conditions and minimizes possibilities of interferences with other links. The power is regulated to the certain selected level based on receiver signal level from the remote station.

## 2.2 THE PROTECTED TERMINAL BOX ALSX

The protected terminal box ALS1x is designated for a concurrent transmission of two Ethernet channels. The protected terminal box ALS1x provides protection of the customer data transmission and the power supply of the station against overvoltage of atmospheric origin. It splits the ODU supply current to all four pairs of conductors of the cable connecting it with ODU. The protected terminal box can be used only with the link type ALxxF MP400/360/165 and AL80GE (see plate at ODU). The numbers in the terminal nameplate is **ALS1-GEth Line3** 121/516 \* 35 (**ALS1-2GEth** 121/516\*30).

Protected terminal box **ALS1x RP** is designed for **power backup**. The numbers in the terminal box nameplate is **ALS1-GEth RP** (121/516\*33) or **ALS1-2GEth RP** (121/516\*34). These terminal boxes are designed for use with MP400/360/165 data links.

Protected terminal box ALS1-GEth + Line2 NMS is designed for separate management. The numbers in the terminal box nameplate is **ALS1-GEth + Line2 NMS** (121/516\*38).

Protected terminal ALS1x is designed for mounting on DIN rail TS35. By giving the three protected terminals can be create a unit for installation in standard 19" 1U. The connection terminals shall be protected by connecting sections. Before inserting the bearing and coupling profiles into terminal slots protected, you need to enable bolts. (Tighten the bolts will provide profiles of anti-slip)

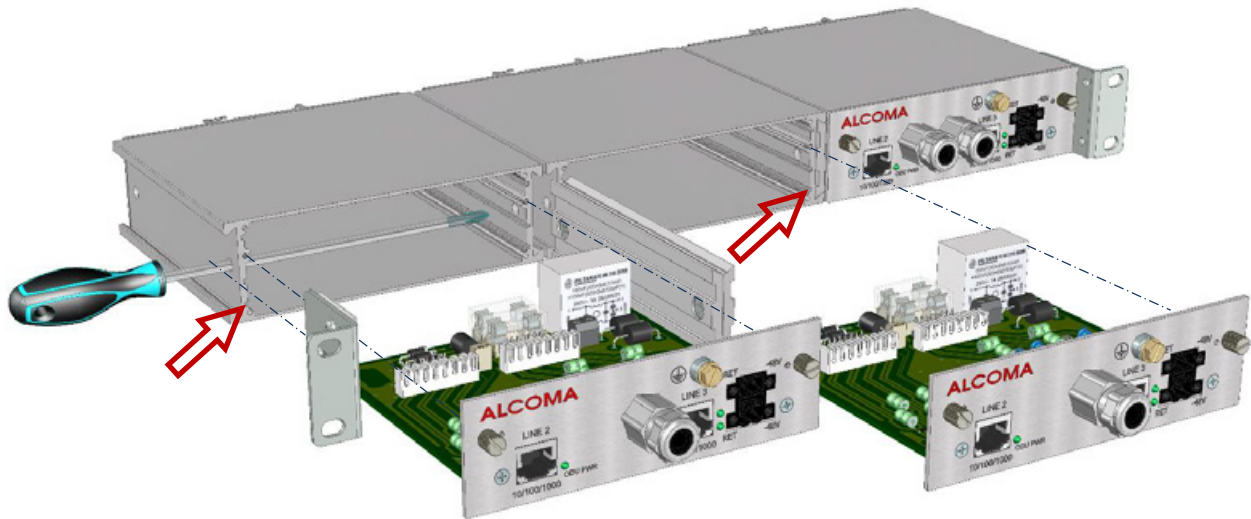

Figure 2 Assembling the three ALS1x to 19" 1U unit



Figure 3 Protected terminal box ALS1-GEth Line 3



Figure 4 Protected terminal box ALS1-GEth Line 2



Figure 5 Protected terminal box ALS1-GEth RP Line 3



Figure 6 Protected terminal box ALS1-GEth RP Line 2



Figure 7 Protected terminal box ALS1-GEth + Line 2 NMS

### 2.2.1 Input Connectors

#### Power supply connector on the front panel

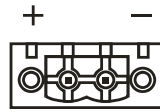

48V DC

The connection cable for this connector ends with the socket type 1777989 Phoenix (0395340002 Molex). Type designation corresponds to the Phoenix (Molex) catalogue.

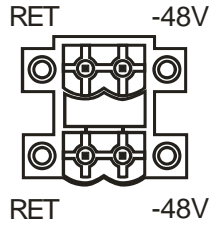

The connection cable for this connector (bottom position) ends with fork type 1777989 Phoenix (0395340002 Molex) and second connection cable for this connector (upper position) ends with fork type 1805301 Phoenix. Type designation corresponds to the catalog Phoenix (Molex)

#### RJ45 connectors for user line input

User Lines 2 and 3

| Wiring  | Pins | Description |
|---|------|-------------|
|  | 1    | A+          |
|   | 2    | A-          |
|   | 3    | B+          |
|   | 4    | C+          |
|   | 5    | C-          |
|   | 6    | B-          |
|   | 7    | D+          |
|   | 8    | D-          |

Table 1 RJ45 connector wiring – user lines Line 2 a Line 3



The AutoMDIX function assures switching of RX and TX as needed.

### 2.2.2 Output Connectors

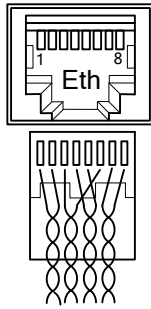
#### Cutting box "Krone" for the Line 2



Line 2 does not contain power feeding.  
(Connector is wired as a mirror of ODU connector).

| Wiring | Pins | Label | The marking of cable conductors<br>S-STP Cat7 |
|--------|------|-------|---|
|        | 1    |       | White   |
|        | 2    | gr    | Green   |
|        | 3    |       | White   |
|        | 4    | or    | Orange  |
|        | 5    | bl    | Blue  |
|        | 6    |       | White   |
|        | 7    |       | White   |
|        | 8    | br    | Brown   |

**Table 2 The protected terminal box - cutting box "KRONE" for the Line 2**

#### 6 pair cable wiring for separate management

Thin pairs of 6 pair cable are connected to cutting box „Krone“ for the **Line 2** according the table 3.



Recommended cable: **ALCOMA UV S-FTP 4+2** part number **893/814\*101-611**

in case you are using a cable with a different color markings of Cat5 conductors, follow these instructions

- first thin pair of conductors connects the green pins between ALS1 and ODU (1-8, 2-7)
- second thin pair of conductors connects the orange pins between ALS1 and ODU (3-6, 4-5)

| Wiring | Pins | Label | The marking of cable conductors<br>S-STP Cat5 |
|--------|------|-------|---|
|        | 1    |       | brown   |
|        | 2    | gr    | blue  |
|        | 3    |       | green   |
|        | 4    | or    | orange  |
|        | 5    | bl    | –   |
|        | 6    |       | –   |
|        | 7    |       | –   |
|        | 8    | br    | –   |

**Table 3 Separate management – The protected terminal box – cutting box "KRONE" for the Line 2**

## Cutting box "Krone" for the Line 3 + Power



Line 2 contains power feeding.  
(Connector is wired as a mirror of ODU connector).

| Wiring | Pins | Label | The marking of cable conductors S-STP Cat7 | Power feeding |
|--------|------|-------|--|---------------|
|        | 1    |       | White                                      | -             |
|        | 2    | gr    | Green                                      | -             |
|        | 3    |       | White                                      | +             |
|        | 4    | or    | Orange                                     | +             |
|        | 5    | bl    | Blue                                       | -             |
|        | 6    |       | White                                      | -             |
|        | 7    |       | White                                      | +             |
|        | 8    | br    | Brown                                      | +             |

**Table 4** The protected terminal box - cutting box "KRONE" for the Line 3 + power



The cable ACOME S-STP Cat7 has its shielding connected to ground through the metal input grommet. If the cable has the shielding coming out through one conductor it can be connected to any shielding pin.

## 2.2.3 Indikace

| Board: Protected terminal box |              |  |
|-------------------------------|--------------|--|
| LED                           | Abbreviation | Meaning  |
|                               | G POWER      | Power ON – indication of the radio station being switched on |

### 2.2.4 Cables in KRONE cutting boxes

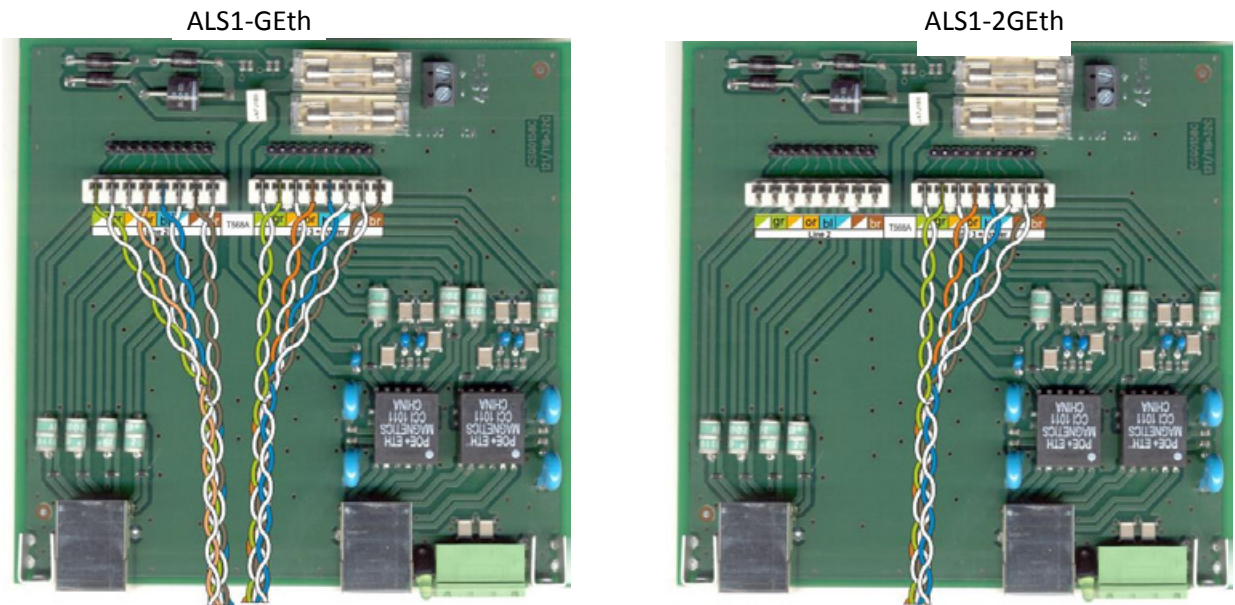

Figure 8 Cable wiring in ALS1-GEth and ALS1-2GEth boxes

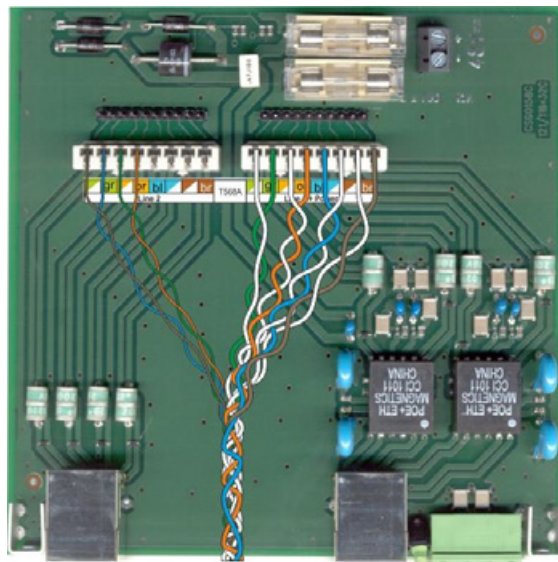
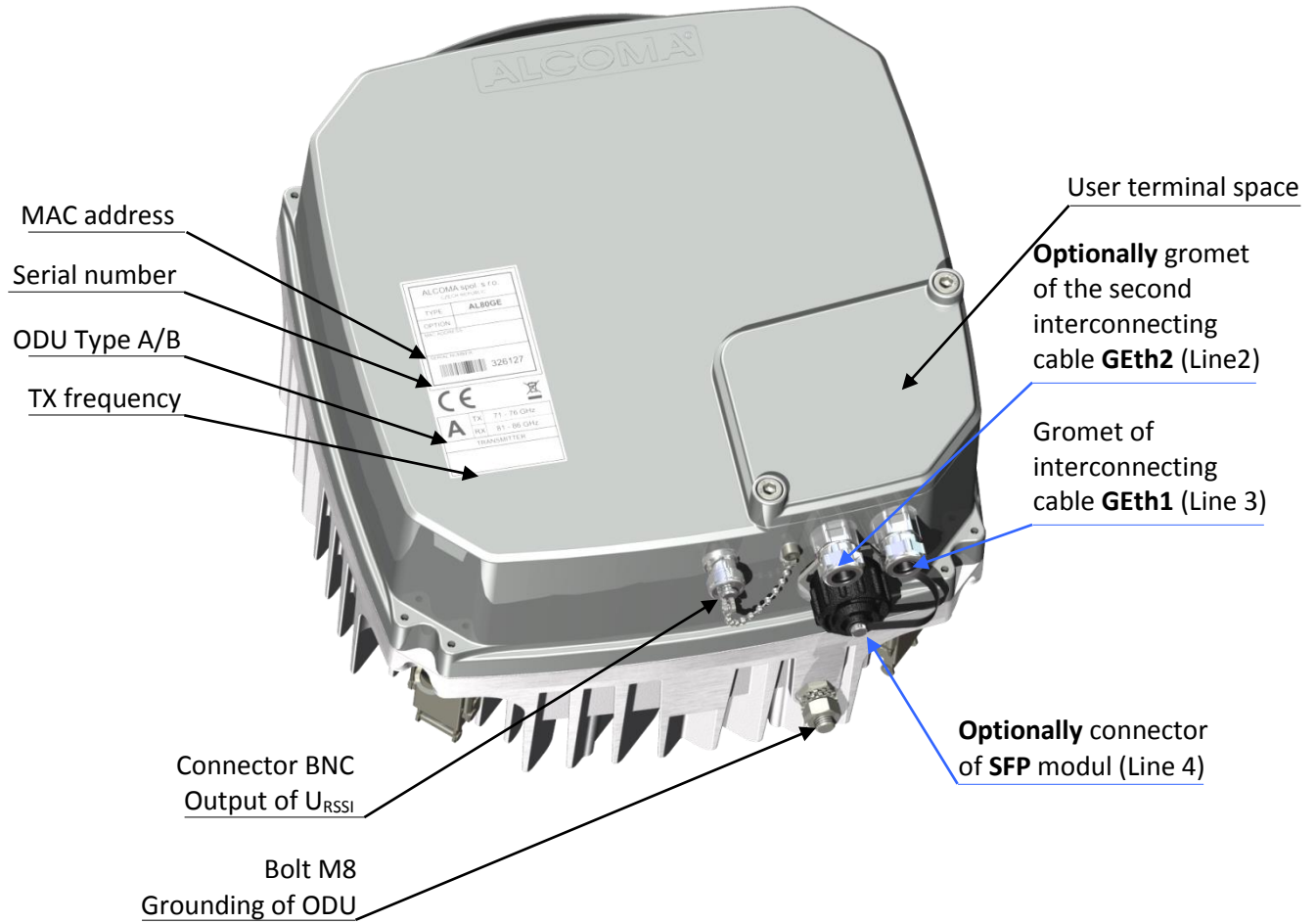

Figure 9 Separate management - wiring in the terminal box

### 2.3 OUTDOOR UNIT (ODU)



**Figure 10 The ODU connection places**

The outdoor unit (ODU) with its microwave and data electronic modules is placed into a metal alloy box with cover allowing opening user terminal space needed for cable connection and diagnostics of the link. ODU can be attached to UNI1-80RFx and UNI2-80RFx antennas by four latches. Feeder is connected to parabola. Antennas stay pointed when ODU must be dismantled.

Input connector

Cutting box „Krone“ for the Line 2

| Wiring | Pins | Label | The marking of cable conductors S-STP Cat7 |
|--------|------|-------|--|
|        | 1    | br    | Brown                                      |
|        | 2    |       | White                                      |
|        | 3    |       | White                                      |
|        | 4    | bl    | Blue                                       |
|        | 5    | or    | Orange                                     |
|        | 6    |       | White                                      |
|        | 7    | gr    | Green                                      |
|        | 8    |       | white                                      |

Table 5 The outdoor unit - cutting box “KRONE” for the Line 2

6 pair cable wiring for separate management

Thin pairs of 6 pair cable are connected to cutting box „Krone“ for the **Line 2** according the table 6.

Recommended cable: **ALCOMA UV S-FTP 4+2** part number **893/814\*101-611**

in case you are using a cable with a different color markings of Cat5 conductors, follow these instructions





- first thin pair of conductors connects the green pins between ODU and ALS1 (8-1, 7-2)
- second thin pair of conductors connects the orange pins between ODU and ALS1 (6-3, 5-4)

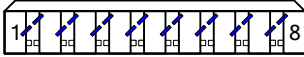

| Wiring | Pins | Label | The marking of cable conductors S-STP Cat7 |
|--------|------|-------|--|
|        | 1    | br    | –  |
|        | 2    |       | –  |
|        | 3    |       | –  |
|        | 4    | bl    | –  |
|        | 5    | or    | orange                                     |
|        | 6    |       | green                                      |
|        | 7    | gr    | blue                                       |
|        | 8    |       | brown                                      |

Table 6 Separate management – The outdoor unit – cutting box “KRONE” for the Line 2

**Cutting box "Krone" for the Line 3 + power**

| Wiring  | Pins | Label   | The marking of cable conductors S-STP Cat7 | Power feeding |
|---|------|---|--|---------------|
|  | 1    | br  | Brown                                      | +             |
|   | 2    |  | White                                      |               |
|   | 3    |  | White                                      | -             |
|   | 4    | bl  | Blue                                       |               |
|   | 5    | or  | Orange                                     | +             |
|   | 6    |  | White                                      |               |
|   | 7    | gr  | Green                                      | -             |
|   | 8    |  | white                                      |               |

**Table 7 The outdoor unit - cutting box "KRONE" for the Line 3 + power**

**Connector for direct connection of power supply**

This connector can be used to power ODU see examples on chapter 3.8, page 28. Description of the pins is shown on the label in the ODU user space. Power supply cord is connected to the terminal block in the user space ODU unused grommet for S-STP cable.

| Wiring  | Pins | Color |
|---|------|-------|
|  | +    | red   |
|   | -    | blue  |

**Table 8 Connector for direct connection of power supply**

**Connector PFL10 for direct connection of PC**

PC running ASD Client can be connected directly to the ODU via connector PFL10. Access to the connector PFL10 is possible after removing the cap user space. On this connector are brought RS232 signals.

| Wiring | Pins | Description |
|--------|------|-------------|
|        | 1    | DCD         |
|        | 2    | DSR         |
|        | 3    | RX          |
|        | 4    | RTS         |
|        | 5    | TX          |
|        | 6    | CTS         |
|        | 7    | -           |
|        | 8    | -           |
|        | 9    | GND         |
|        | 10   | -           |

**Table 9 Connector PFL10 for direct connection of PC**

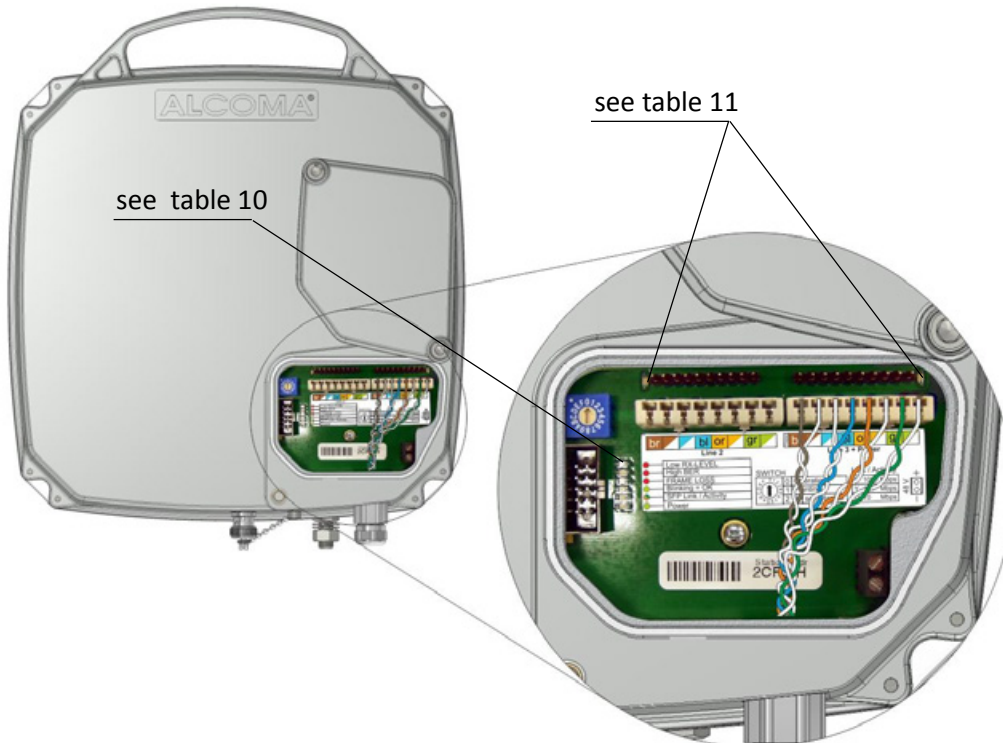

**Figure 11 User space ODU 1xGEth**

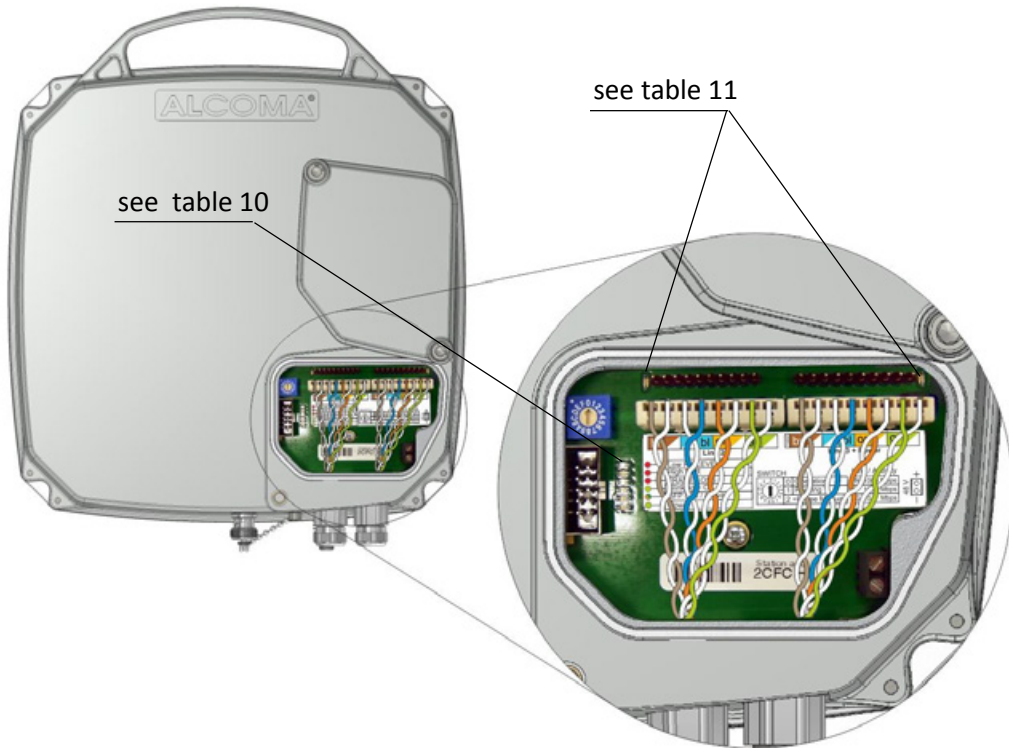

Figure 12 User space ODU 2xGEth

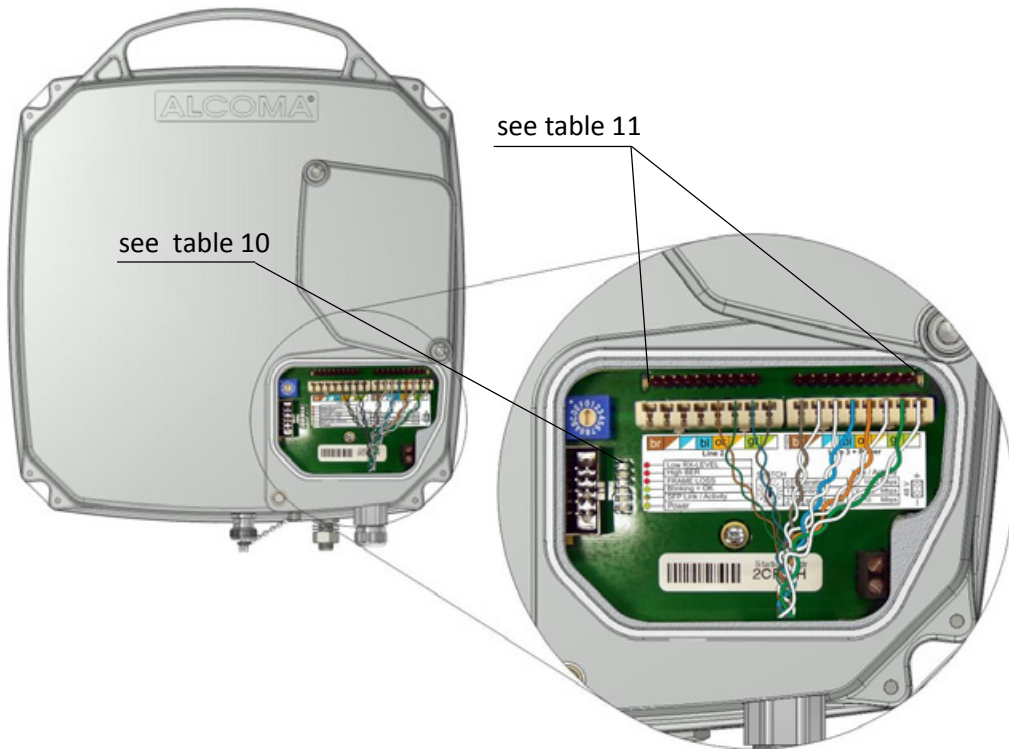











Figure 13 The ODU user space 1xGEth separate management

**Indication**

| LED  | Description         | Meaning  |
|--|---------------------|--|
|  R  | RX LEVEL LOW        | Low level of the input microwave signal  |
|  R  | HIGH BER            | Increased errors on the microwave path   |
|  R  | FRAME LOSS          | Loss of frame sync   |
|  G  | OK                  | Blinks = monitoring system does not register any error states at the moment. Light on / Light off = monitoring system indicates an error state |
|  YG | SFP Link / Activity | Orange = Link on SFP.Green = activity  |
|  G  | Power               | Indication for stable output voltage of +3.3 V   |

**Table 10 Meaning of LEDs in the ODU user space**

| colour of LED   | Meaning        |
|---|----------------|
|  R   | Link 1000 Mbps |
|  RG | Link 100 Mbps  |
|  G | Link 10 Mbps   |
| Blinking  | Traffic        |

**Table 11 Meaning of LEDs next the cutting box “KRONE” in the ODU user space**

**Rotary switch functions**

The rotary switch is located on the mother board. It is accessible after flipping off the lid on the ODU cover. The station does not have any other elements that can be changed during normal operation.

| Position | Description              |
|----------|--------------------------|
| 0        | Normal station operation |
| 1        | Pointing                 |
| 2 ÷ F    | Reserve – not used yet   |

**Table 12 Description of functions of the rotary switch in the ODU user space**

The rotary switch in the position Pointing (1) also switches off a transmitter of the local station. Switching off of the output also in the remote station by the rotary switch can be used to find a level of interference signals (background noise) on given channels.

The AL80GE station is optimally tuned during manufacture, set and tested in accordance with guaranteed parameters and customer requirements. If there is a new requirement to retune to a different channel or for a configuration change (possible on this equipment) after installation or inspection, it is possible to do this work using the monitoring program only. Retuning to a different frequency range that requires replacement of microwave filters can be done at the manufacturer only.

### 3. INSTALLATION INSTRUCTIONS

#### 3.1 STATION INSTALLATION



**Warning!**

Low voltage equipment, electromagnetic and telecommunication standards are applicable to radio relay link AL80GE.



**Warning!**

The radio relay link AL80GE is not intended to be used by non-specialist personnel. Installation, adjusting and maintenance must be performed by the manufacturer instructed personnel with electrotechnical qualifications.

**Allowed installation torques:**

| Bolt and nut | Torque |
|--------------|--------|
| M10          | 35 Nm  |
| M8           | 17 Nm  |
| M6           | 11 Nm  |
| M5           | 5 Nm   |
| M4           | 3 Nm   |



All bolts and nuts should be greased before installation.

#### 3.2 EVALUATION OF SUITABLE PLACEMENT

For installation and proper operation of the radio link the following must be provided:

- Direct optical visibility
- Place for attachment of antenna with ODU
- A place for the protected terminal box ALS1x
- Path to lay the ODU – ALS1x connection cable

Guaranteed direct visibility is not always sufficient guarantee of a quality connection. A condition for a trouble free propagation of electromagnetic waves is a pure radio visibility. If fixed objects, like tree tops, mountains or buildings are too close to the signal route, they can distort or attenuate a radio signal. This occurs even in cases when these obstructions do not prevent direct visibility. This phenomenon can be explained by the radio beam Fresnel zone – an elliptical area that immediately surrounds the direct visibility axis (the line between link antennas). Size of this zone varies depending on the hop length and radio signal frequency. The Fresnel zone must be calculated before design of the wireless link and it must be verified that it will not be disturbed by any obstacles.

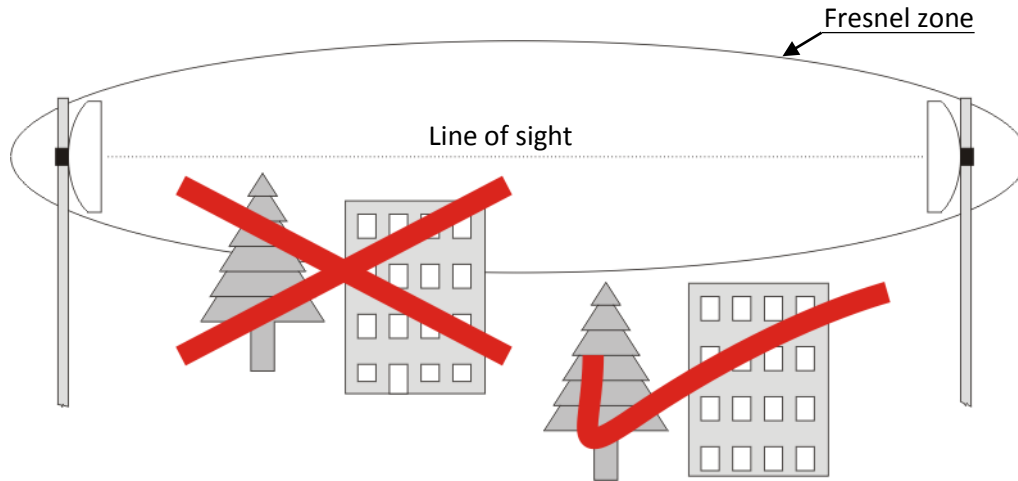

Figure 14 The Fresnel zone

Figure 15 shows situation when a solid object penetrates a Fresnel zone of signal propagation. The obstacle, just like the one on the figure, causes bending of the beam along the sharp edge. This beam then arrives at the receiver antenna little bit later than the direct beam. In other words there are two identical signals coming to the antenna, but with various phases, which strongly degrades the signal quality; and this can cause temporary break in data transmission. Trees or other “soft” objects infringing on the Fresnel zone attenuate the radio signal. In short: The fact that you can see the opposite side does not mean that you can set up a quality radio link.

### 3.3 PLACEMENT OF THE ANTENNA ON A SUPPORT CONSTRUCTION

The antenna of radio link must be placed sufficiently far away from other antennas, in order to avoid undesirable perturbation of radio signal. Badly installed antenna will cause deterioration of our transmitted signal and also of the signals of neighboring links. During installation of a radio relay link we need to calculate with a distance from the roof edge or different obstacles that can be present on the roof (A/C, elevator shaft...). The following figures show incorrect and correct ways of installation of radio relay link antenna on the supporting construction.

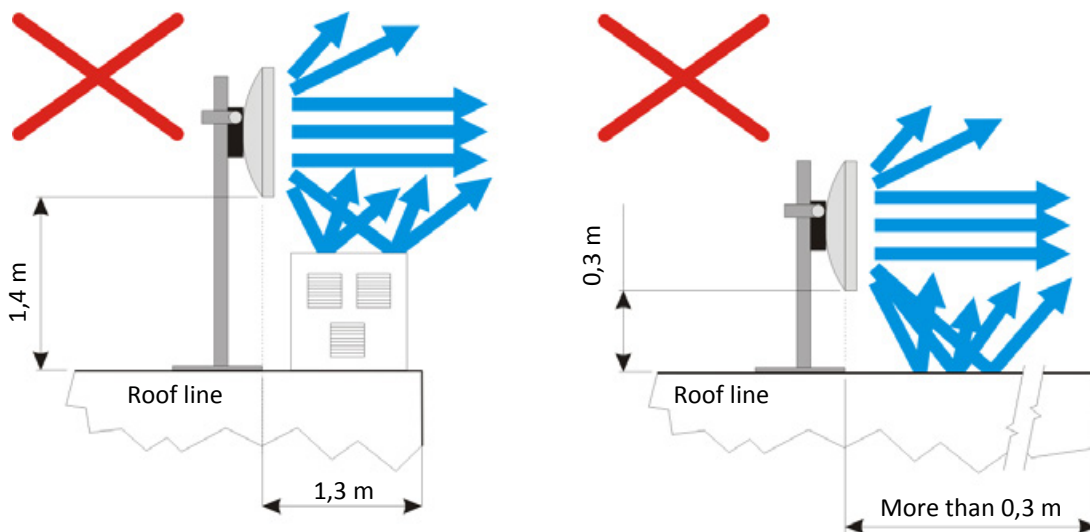

Figure 15 Improper placement of antenna on mounting pipe

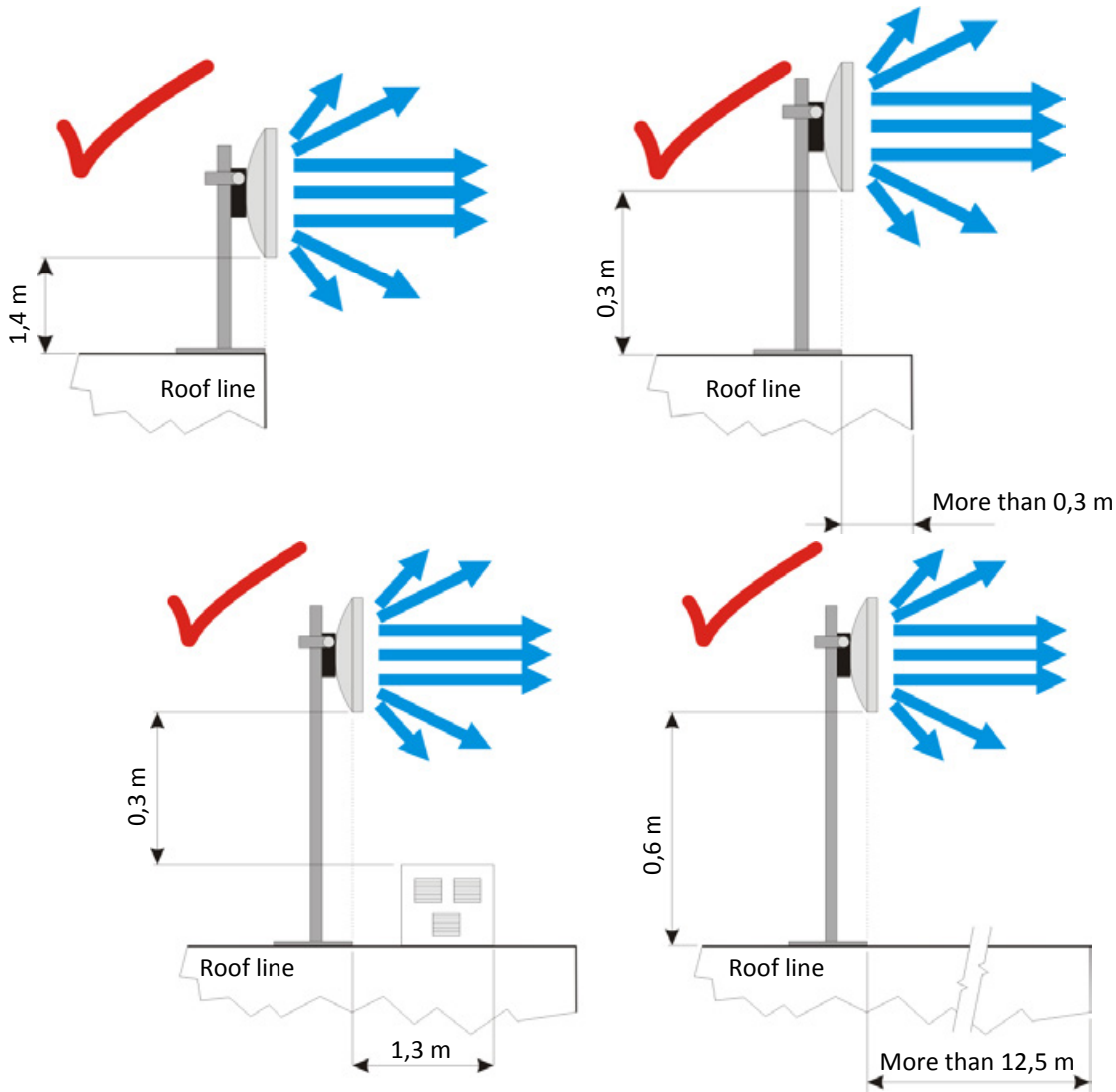

Figure 16 Proper placement of antenna on mounting pipe

|                                      |     |     |     |     |     |     |     |     |     |     |     |     |     |     |       |
|--------------------------------------|-----|-----|-----|-----|-----|-----|-----|-----|-----|-----|-----|-----|-----|-----|-------|
| Obstacle distance [m]                | 0   | 0.3 | 0.6 | 0.9 | 1.2 | 1.5 | 1.8 | 2.1 | 2.4 | 2.8 | 3.1 | 6.1 | 9.2 | 12  | >12.5 |
| Height of antenna above obstacle [m] | 0.3 | 0.6 | 0.9 | 1.2 | 1.3 | 1.4 | 1.4 | 1.4 | 1.4 | 1.5 | 1.5 | 1.8 | 2.1 | 2.3 | 2.5   |

Table 13 Recommended antenna placements considering a distance from an obstacle<sup>1</sup>

<sup>1</sup> Table values correspond to an average antenna size and normal climatic conditions. Parameters of the used radio link type and climatic conditions have to be always taken into account.

### 3.4 LOCAL FREQUENCY COORDINATION

The following picture shows possible local frequency coordination in unlicensed/uncoordinated frequency band. Placement of antennas is shown only as one of possible recommendations. If there is more 80 GHz frequency band radio links in one location, polarization, or possibly link channel numbers must be selected to eliminate undesirable interference. The following Figure 17 shows possible polarization combinations.

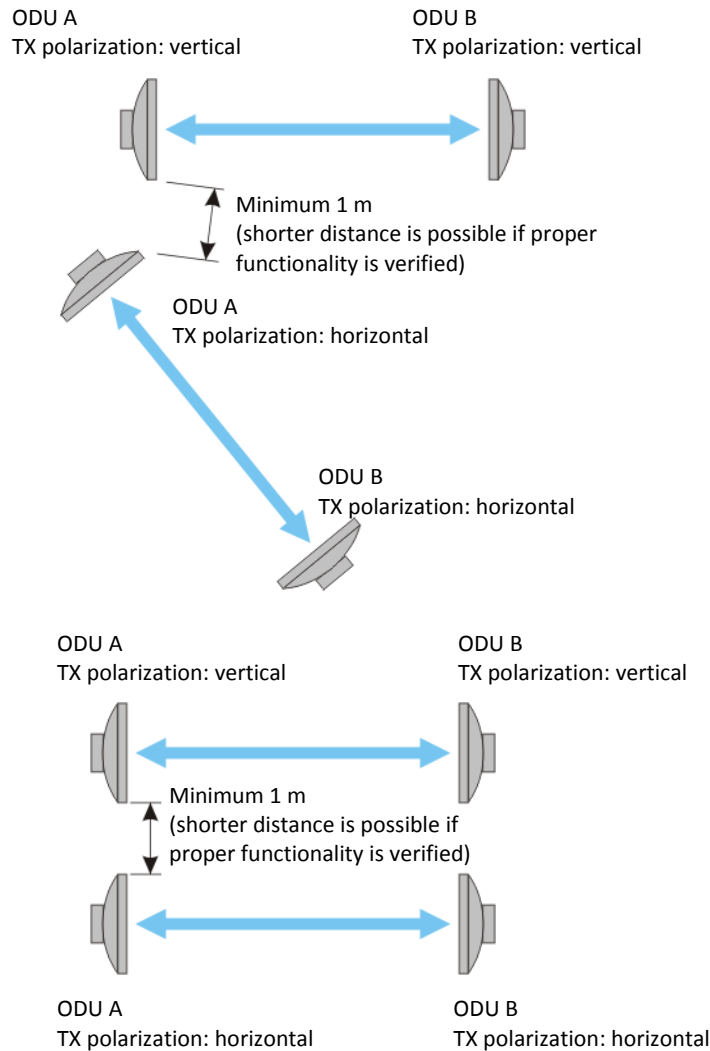

Figure 17 The examples of channel and polarization usage in case of more links in one location

### 3.5 INSTALLATION OF THE ANTENNA SYSTEMS

Station antenna systems are attached to a vertical steel pipe that is a part of a girder mast structure, or to other steel constructions firmly connected to the building, on which the station is being installed. Diameters of supporting pipes are set by the Table 20 on the page 51.

The antenna unit may not be installed on building equipment that have not been set or modified for this purpose.

### 3.5.1 UNI1-80RF (UNI2-80RF) antenna

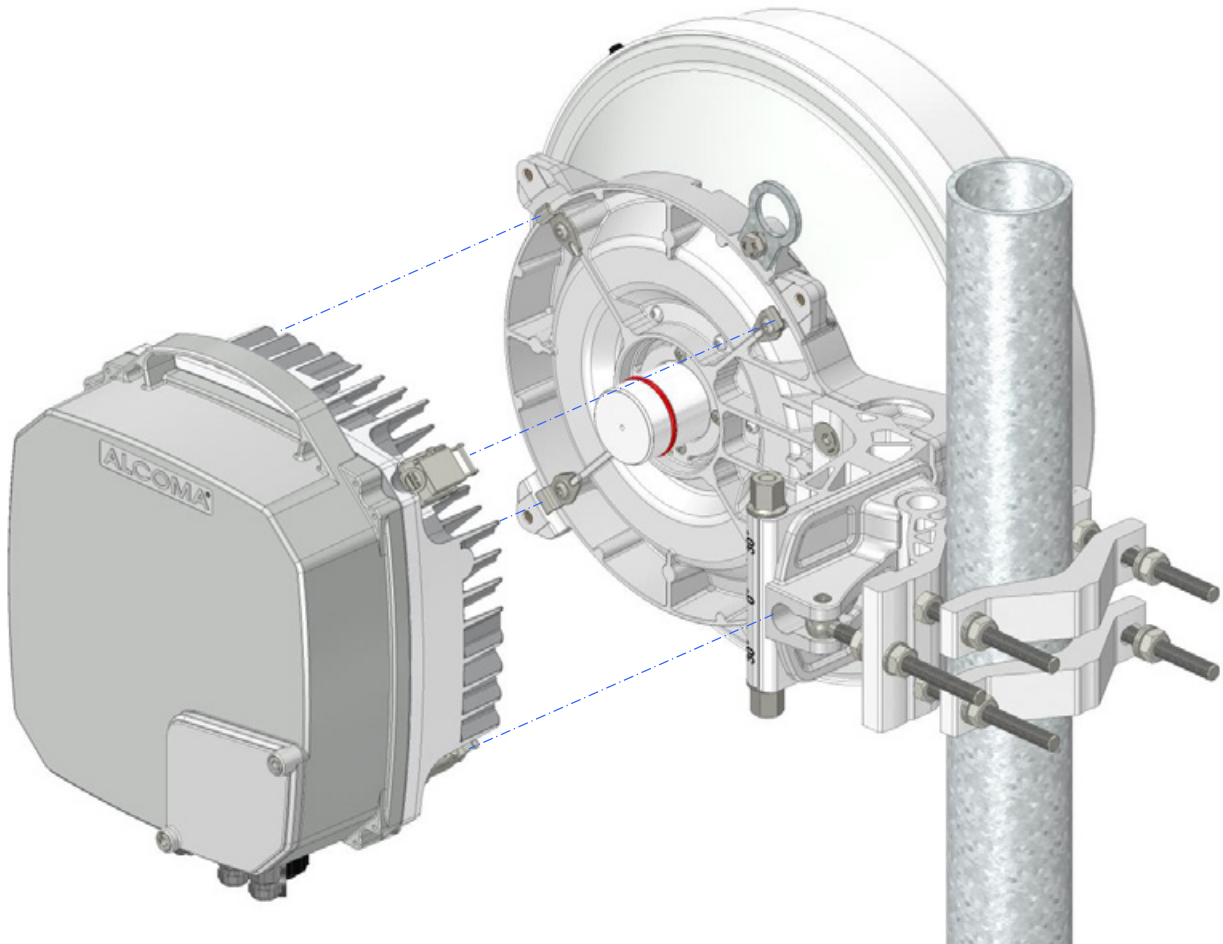

**Figure 18 ODU attachment to UNI1-80RF (UNI2-80RF) antenna**

- Feeder is integrated in antenna.
- ODU is attached to antenna by four latches for easier installation/deinstallation.

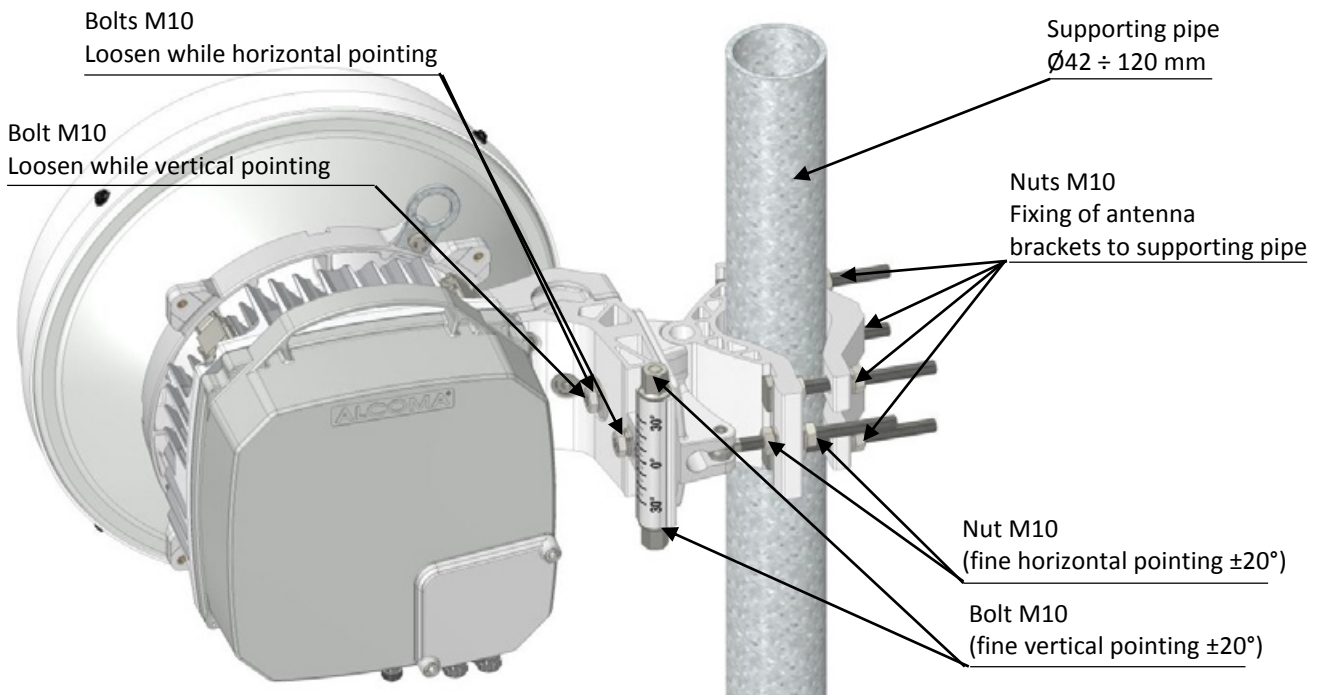

**Figure 19 Attachment of UNI1-80RF (UNI2-80RF) antenna holder**

The attachment of ODU with antenna must be sufficiently rigid to withstand wind acting on the ODU without making the link to point in a wrong direction (the main lobe width is  $0.9^\circ$  and  $0.5^\circ$ ). These forces are primarily caused by the front wind resistance of the microwave antenna.

The ODU box is installed with the gromet of connection cable **pointing down with the horizontal polarization** or to the **side with the vertical one**. It is never installed with the gromet pointing up. Possible disassembly can be performed without affecting the link pointing direction.

For easy pulling up of ODU with the antenna to a mast or a support pipe, lifting lug that is approx. above the center of gravity of this system can be used.

Please note that, according to the Safety Notices workers must be equipped by PPE, especially a hard hat, during work on masts and in their proximity.

**Firm tightening of all connections of an antenna system must be checked after installation.** We especially note the tightening of the antenna unit brackets to the antenna support pipe and of the bolts that secure the vertical setting.

### 3.6 GROUNDING



**CAUTION**

The antenna support pipe, antenna system, and the ODU box must be properly connected and grounded with regard to discharges of atmospheric energy. Always refer to local valid standards and regulations.

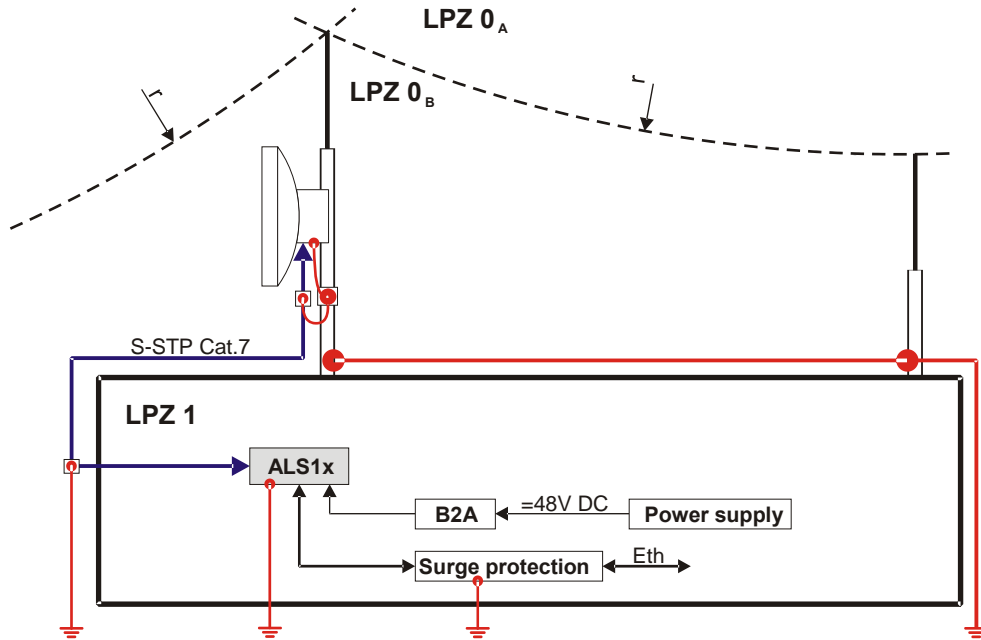

**Figure 20 The terminal grounding**

A support pipe in a stand or lattice mast must be grounded by a steel galvanized wire or a copper wire with a cross section of at least 50 mm<sup>2</sup>. Also the ODU box and the antenna system must be grounded, best by a copper rope with the cross section of at least 14 mm<sup>2</sup> that is ended by a cable eyelet. The brass bolt M8 with the grounding rope eyelet is screwed into the marked hole at the bottom of ODU that is placed under the connection cable grommet.

The antenna system grounding points of UNI1-80RF and UNI2-80RF antennas are common with those of ODU.

This whole equipment should be, if possible, located in the space that is protected by lightning traps against direct lightning strike. If this cannot be guaranteed even through installation of additional traps, then other corresponding modifications must be performed according to the EN 62305-4 (Protection against lightning) standard and after consultation with a professional.

The protected terminal box ALS1x in a building is grounded by a copper rope with the cross section of at least 5 mm<sup>2</sup> with cable eyelets. This cable should be connected to the marked M4 pin on the front side of ALS1x.

### 3.7 ATTACHMENT OF FEEDER TO THE ANTENNA



#### Caution

Feeder can be damaged while inexperienced installation/deinstallation of ODU. Feeder is a precise element, manipulate it carefully. Any damage may cause improper function of the whole link.

Feeder and antenna are one whole. Attach the feeder to the antenna according to the following steps when delivered separately:

- Check that "O" ring is slipped on feeder.
- Attach the feeder to the antenna using 4 M4 bolts (Figure 21).

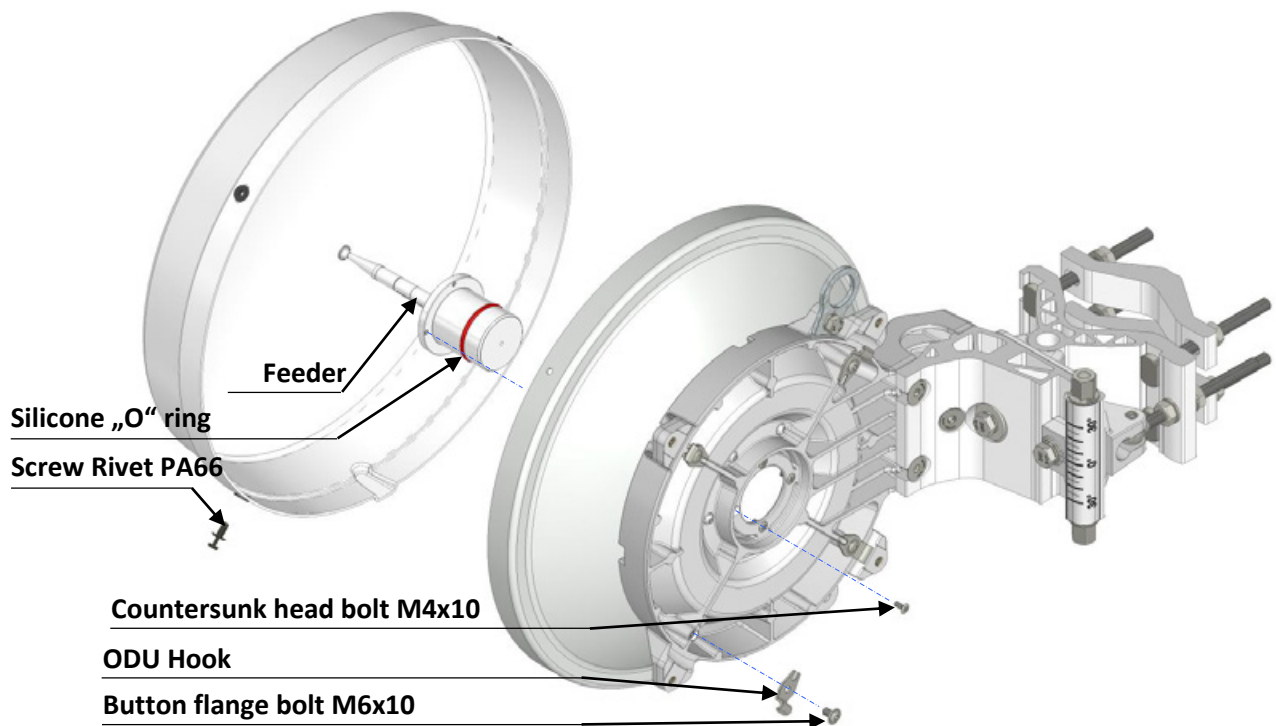

Figure 21 Attachment of feeder to the UNI1-80RF (UNI2-80RF) antenna



#### CAUTION

Make sure that flange sealing ("O" ring) is on its place and it is not damaged.

### 3.8 TYPICAL ODU WIRING

Typical AL80GE ODU wiring is shown on the following pictures. Separate power feeding and Line 4 optical connection may be used. This may help when different grounding potentials are between ODU and ALS1x and improves safety and immunity against atmospheric electrical discharges. ODU power feeding uses cable connected to Line 3 + POWER "KRONE" cutting box.

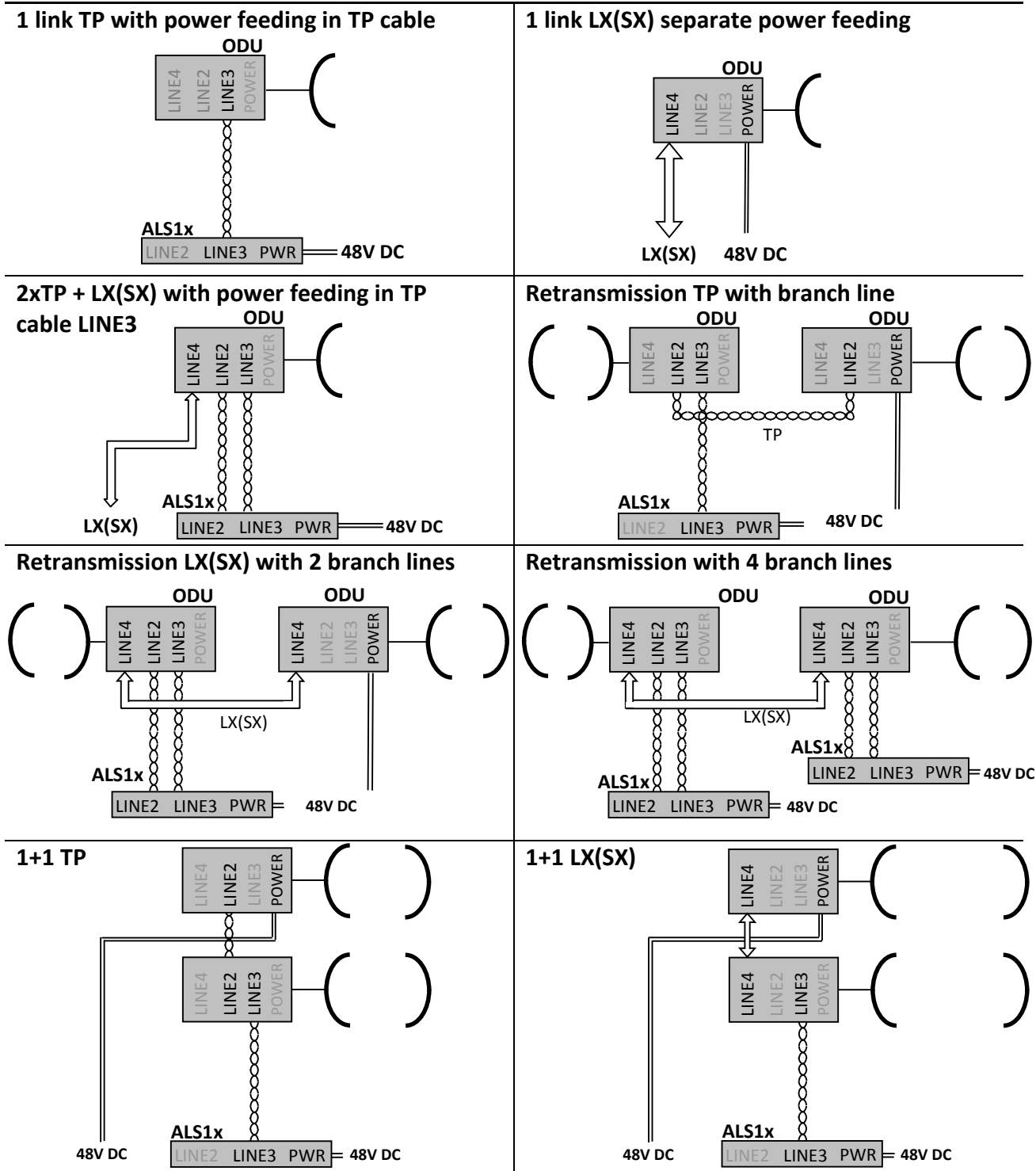

Figure 22 Typical ODU wiring

### 3.9 USER SPACE COVER HANDLING

The user space cover enables access to the user interfaces for connection and diagnostics of ODU only. This eliminates a possibility of undesirable interference into other ODU parts.

The cover is attached by 2 M6 bolts that can be unscrewed by an Allen wrench no. 5. One of the bolts can be only partially loosened, which ensures attachment to the box during manipulation with the cover. Retightening of this bolt in open position enables locking of the lid in any position.

Since the user buses are located in the inside hermetically enclosed space of the box, the lid is provided with a gasket. To protect the gasket from damage, please rigorously keep the safety notice specified below.

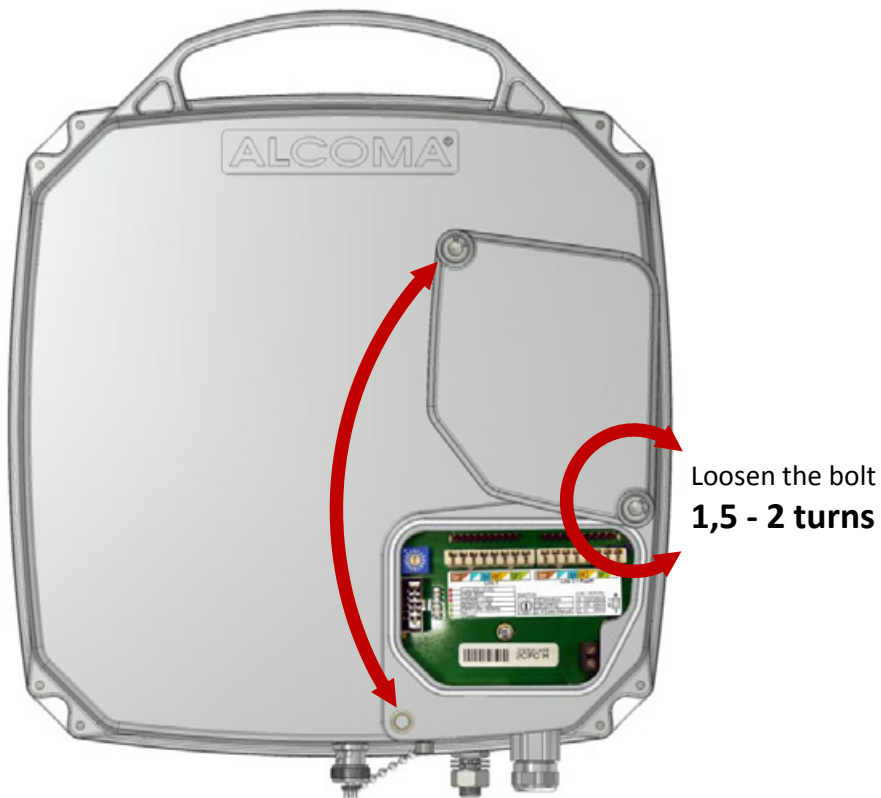

Figure 23 Manipulation with the user space cover

#### Warning



The bolt that ensures attachment of the cover during manipulation must be loosened at least by 1.5 to 2 turns during moving of the cover. In case that the **bolt is tightened during moving of the cover** more or completely, the gasket is sliding over the box sharp edges that **can damage the gasket seriously**.

### 3.10 INSTALLATION OF INTERCONNECT CABLE

We recommend using the **shielded cable for outside use** by ACOME, type **Cat 7 S-STP**, or the type Telco 100 W 4\*ISTP from Belden Wire, with four pairs of conductors for the connection of the terminal box ALSx and the station AL80GE. The cable is led into the link box through a sealing grommet that prevents penetration of climatic humidity from the surroundings and shows sufficient shielding necessary for keeping of electromagnetic compatibility of the whole device at the same time.

The connection cable must not be mechanically loaded. It has to be protected by a flexible electric installation pipe, especially in the outside environment, and attached so the mechanical loading is out of the question. We recommend using the electric installation pipe type HFX 16 by Dietzel Univolt.

It is necessary to keep a minimum curvature during installation and attachment of the cable. The critical spot, especially for vertical polarization, is at the outlet of the connection cable from ODU.

ALCOMA completes the radio relay system deliveries by the modified cable of the type Cat 7 S-STP from ACOME. Additional outside insulation of the cable increases its climate resistance and also resistance against the sun UV radiation.

#### The procedure during installation of ACOME cable type Cat 7 S-STP

(Identical for the protected terminal box and ODU)

- The cover of the protected terminal box is removed using a Phillips screwdriver (Figure 11) or the cover of the terminal box space in ODU is opened using an Allen wrench no. 5 (Figure 11).
- The pull-over nut and the sealing grommet are placed over the cable. The top 25 cm of PVC cable cover from the cable end will be removed. The silk guiding thread also needs to be cut.
- The shielding has to be compressed a little, and the conductors need to be cut by about 2 cm. Thus created overlapping shielding will be twisted together.
- The bottom washer, spring washer, and the top washer (in this order) will be pulled over the cable and pushed against the PVC cable cover.
- The twisted shield will be untwisted and released somewhat. Then it will be pulled over the washers on the cable and shortened at the bottom washer (figure 24). No wire of the shielding must go over the bottom washer, in order to tighten the sealing grommet by the pull-over nut well on the cable, and thus seal the grommet properly.
- Shielding of individual pairs will be removed all the way to the turned over top braiding.
- The cable will be inserted through the grommet, and the pulled-over nut will be completely tightened.
- The individual pairs will be divided to the internal Krone connectors that are color coded and numbered on the PCB sticker according to the color codes (for the Cat7 S-STP cable), or numbers (for the Telco 100  $\Omega$  4\*ISTP code).
- The individual conductors will be connected using the pusher knife for Krone connectors. The conductor insulation is not removed. It automatically cuts through by the knife connector contacts during installation. The conductors are automatically cut to necessary length at the same time. The cutaway ends must be removed. That is why individual conductor lengths must be sufficient in order to be able to hold the cut off ends in hand during cutting into the connector. Removing them will prevent possible defects.
- The cable installation will be finished by the reinstallation of removed cover. The attachment screws are tightened by a Phillips screwdriver or an Allen wrench.

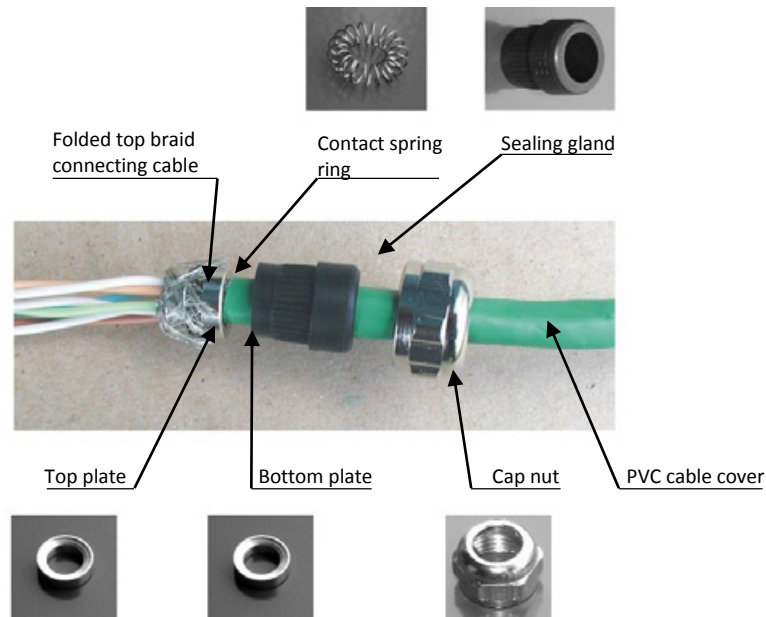

Figure 24 The grommet installation

If a customer uses a different cable than the recommended type Cat 7 S-STP by ACOME, the installation is similar. If the cable has separate shielding for each pair of conductors, then the shielding must be connected according to the marking on the Krone connectors. In cables with only one shielding cable taken out the shielding is connected to any shielding pin.

Corresponding after installation tightness of the grommet must be ensured for these customer selected cables too.

**CAUTION**



It is not allowed to unscrew the grommet from the ODU wall under any circumstances. This grommet is hermetically sealed and this seal would be damaged during disassembly. Caution! Do not **loose washers and a spring ring** if you **straighten the bent shielding** of the connection cable during disassembly of the cable

ODU AL80GE

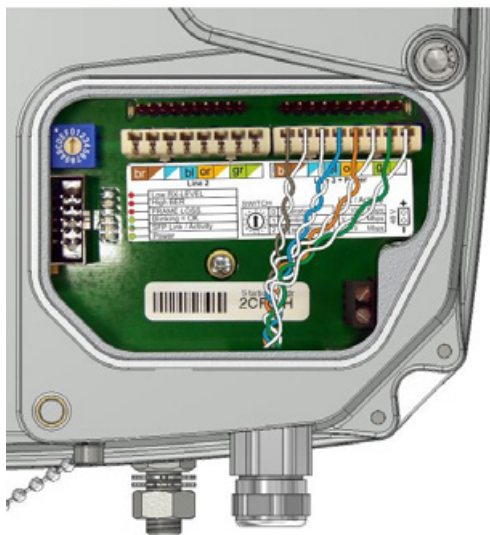

Protected terminal box ALS1-GEth

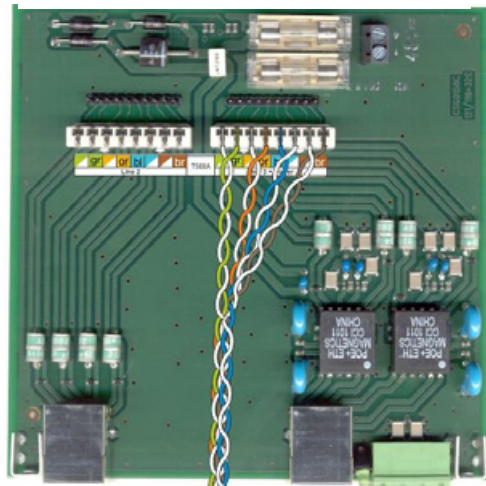

Figure 25 Finished assembly of the connection cable Cat7 S-STP

### 3.11 SFP OPTIONAL MODULES

ODU can be extended using optional SFP modules. We recommend to use Finisar modules, which were tested with ALCOMA links. SFP module replacement is possible only in ALCOMA production plant.



1000Base-LX  
Singlemode (1310 nm)



1000Base-SX  
Multimode (850 nm)



1000Base-BX  
WDM Singlemode (TX 1310 nm – RX 1550 nm)



1000Base-BX  
WDM Singlemode (TX 1550 nm – RX 1310 nm)

Figure 26 Optional SFP modules

Modules can be installed only to ODUs equipped with special connector – see the following picture. Connector enables safe connection of metallic or optical interface regarding on used SFP module type.



**CAUTION**

Observe the general rules for work with optical cables, especially care about cleanness of optical connectors.

Use safety cover for optical interface when manipulate with SPF module.

## 3.12 INSTALLATION OF OPTICAL CONNECTOR MOLEX 106059

### 3.12.1 Package content

1. Dust cover
2. Connector case
3. Bayonet nut
4. Securing cable nut
5. LC 3 mm connector body with injection pipe for glue 2x
6. LC crimp ring 2x
7. Duplex junction (upper and lower)



### 3.12.2 Optical cable preparation

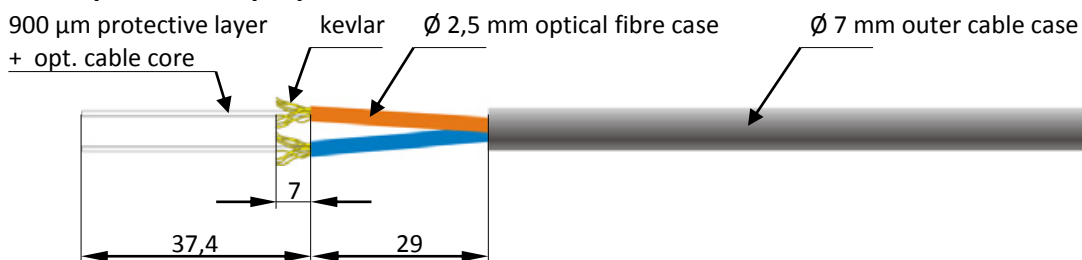

### 3.12.3 Connector assembling

1. Slip securing cable nut, bayonet nut and connector case to the cable.
2. Prepare optical cable according to the sketch above.
3. Slip crimp ring (1 ring to 1 fibre).
4. Inject glue through the pipe to the connector case<sup>2</sup>.
5. Take out the injection pipe.
6. Apply activator to protective layer of the fibre.
7. Slip the connector body up to the optical fibre case.
8. Shift crimp ring over kevlar and connector body back end. Oring is on the right when looking to the connector from the back and locks on body are oriented upwards.
9. Crimp the ring.
10. Cut optical fibre overlap upright, clean, file and polish the fibre.
11. Check whether the cut is clean and upright polished.
12. Attach upper and lower junction to LC connector body.
13. Assembling of connector.

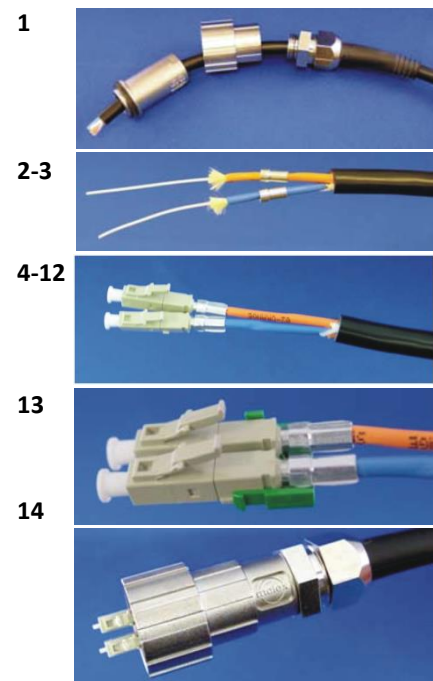

The opposite end of the cable must be connectorized in the way that each optical fibre connects optical transmitter with optical receiver.

<sup>2</sup> LOCTITE 638 glue + activator 7649 are recommended

### 3.13 BEFORE PUTTING THE RADIO LINK INTO OPERATION

Before putting the radio link into operation the user must verify, whether he has available documents certified by the distributor that verify that the product is in safe condition.

The manufacturer delivers “Measuring and Testing Protocol” together with the radio link, based on a special request, where basic electrical parameters measured during activation and adjusting of the connection are specified.

### 3.14 ACCESSORIES

Based on customer wishes we can deliver all accessories necessary for installation and service of the radio relay links AL80GE:

- interconnect cables
- KRONE pusher knife
- Lockable 19“ standard installation cabinets
- For the attachment of antenna systems and outdoor units:
  - High and low stands  $\varnothing$  76 mm a  $\varnothing$  102 mm.
  - Side and outside brackets
  - Brackets for walls and poles
  - Special brackets according to customer wishes or needs

Mechanical constructions that show requested strength, rigidity, and atmospheric resistance, and that it can be used according to actual needs.

- DC Power supply with requested characteristics.
- Overvoltage protection for the power supply.
- Cables to connect monitoring PC

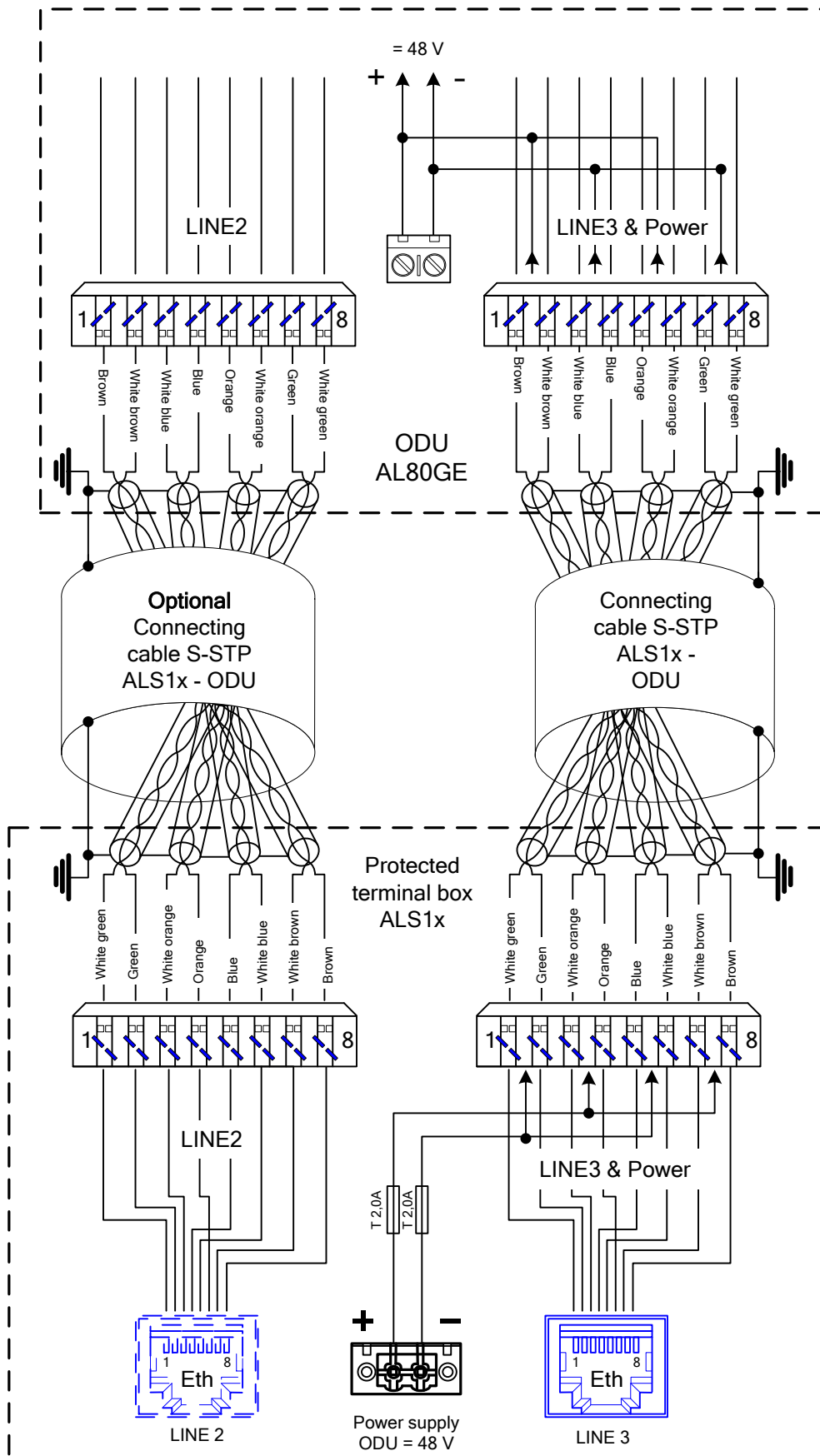

**Figure 27 Connection of the connecting cable**

## 4. SETTING OF THE RADIO LINK AND ITS COMMISSIONING

Installation and commissioning of the radio relay AL80GE radio link can be performed by the manufacturer or by a person or company authorized by him only. The power feeding can be performed by certified power supply from low voltage power grid, whose technical condition and manner of protection against electric current injury meets conditions of related regulations. The user must verify whether the ODU supply voltage agrees with the output voltage of a power supply. Electric power network, to which the product will be connected, must be initially inspected according to the appropriate standards.

For reasons of achieving high operational reliability, parameter stability and long life the units (even enclosed in a cabinet) may not be placed near heat, water, dust, or vibration sources etc.

The ALCOMA ODU units do not contain any adjustment or tuning elements that would have to be modified during commissioning by customers. The units are delivered tuned and tested. Removal of possible defects and failures within the warranty period is done by the manufacturer or a company authorized by the manufacturer. Any manipulation with adjustment elements is prohibited. Any unprofessional interference with the equipment, especially manipulation with adjustment elements, voids the warranty.



### CAUTION

An outdoor unit and a protected terminal box must be properly connected to a protection cable, and grounding must be performed due to atmospheric electricity charges. (According to Communication line and equipment protection against atmospheric overvoltage and overcurrent regulations).

In case of longer keeping in stock (months) please check setup of real time in about 10 minutes after switching on. Data are backed up by high capacity capacitor.

## 4.1 POINTING OF RADIO RELAY LINK



**TX power must be reduced before starting pointing to avoid destruction of microwave receiver. Maximum allowed input signal level of the receiver is -20dBm!!**

Maximum TX power for different combinations of antenna diameters and link distances are shown in the table below. Do not exceed the maximum input signal level on receiver.

| Parabolas 2x UNI2-80RF (2 x 51 dB)              |       |      |      |      |      |      |      |      |      |
|---|-------|------|------|------|------|------|------|------|------|
| Hop lenght [km]                                 | 0.1   | 0.5  | 1.0  | 1.5  | 2.0  | 2.5  | 3.0  | 3.5  | 4.0  |
| TX power [dBm]                                  | -11.0 | 2.9  | 9.0  | 12.5 | 15.0 | 17.0 | 18.5 | 19.8 | 21.0 |
| Parabolas UNI1-80RF (46 dB) + UNI2-80RF (51 dB) |       |      |      |      |      |      |      |      |      |
| Hop lenght [km]                                 | 0.1   | 0.5  | 1.0  | 1.5  | 2.0  | 2.5  | 3.0  | 3.5  | 4.0  |
| TX power [dBm]                                  | -6.1  | 7.9  | 14.0 | 17.5 | 20.0 | 21.9 | 23.5 | 24.8 | 26.0 |
| Parabolas 2x UNI1-80RF (2 x 46 dB)              |       |      |      |      |      |      |      |      |      |
| Hop lenght [km]                                 | 0.1   | 0.5  | 1.0  | 1.5  | 2.0  | 2.5  | 3.0  | 3.5  | 4.0  |
| TX power [dBm]                                  | -1.1  | 12.9 | 18.9 | 22.5 | 25.0 | 26.9 | 28.5 | 29.8 | 31.0 |

**Table 14 Max. TX power values depending on antennas and distance**

Pointing should be done while the weather is stable and suitable without having influence of transmitting conditions. It is better to interrupt pointing procedure and wait when meteorological conditions (rain, snow) can have influence on sudden RX signal level changes.

Pointing means turning antennas in both directions to achieve the best RX signal level value. After rough pointing with TX power limited according to table 14 (ATPC switched off) we recommend to decrease TX power for additional 10dB for fine pointing. Optimum pointing RSSI value is between -30 dBm and -50 dBm, which guarantees that receiver circuits are not overloaded during pointing.

Pointing should be done in several steps in both horizontal and vertical directions. Pointing should be done step by step on both link's terminal station, never point both terminal stations simultaneously.

At the beginning of pointing both opposite stations must already be roughly adjusted and switched on in order to pick up their signals. Maximum RX level must be found on the main lobe of the antenna radiation diagram (figure 30), remember that the main lobe width is **0,9° for UNI1-80RF and 0,5° for UNI2-80RF**.

To make pointing easier, ODU has the built in acoustic signalization of the size of received signal level that can be switched on by a rotary switch at the user space (figure 11).



**RX Level on the main lobe is 13 dB higher than on the first side lobes.**

**Pointing Procedure:**

- Loosen all M10 nuts (bolts) of the antenna fixing antenna position in horizontal or vertical direction.
- Using an Allen wrench no. 5 loosen and flip up the cover on the ODU box (see the chapter 9 on the page 5).
- After removing the BNC connector cover at the bottom part of the ODU box connect DC voltmeter set to the min. range of 5 V to it. It is more advantageous to use an analog voltmeter for easier reading while searching for a maximum value. (In a pinch you can connect a DC ampere meter with the min. range of 5 mA).
- The rotary switch needs to be moved to the pointing position. Base tone of acoustic signalization sounds, which by its pitch (not intensity) corresponds to the strength of received signal. A deep (base) tone sounds when the unit does not receive any signal, or the signal is very weak. The tone (voltage on  $U_{RSSI}$ ) increases in jumps, since it is digitally linearized.
- After switching the rotary switch, it is good to wait with reading of URSSI about 5 s for the ATPC system to stabilize (if switched on).
- Tighten all M10 nuts (bolts) when pointing is finished. Move the rotary switch to the zero position. Tighten the user space cover.

**CAUTION**

The rotary switch in the position Pointing also switches off a transmitter of the local station. Switching off of the output also in the remote station by the rotary switch can be used to find a level of interference signals (background noise) on given channels.

**Rough Adjustment**

The rough adjustment can be done “by eye” using binoculars rested against the antenna. If the visibility is bad, or distance is too long, you need to determine the azimuth first using a compass.

Caution! Compass measurement accuracy is limited by steel mast construction! The rough pointing should have a variation of max.  $\pm 5^\circ$  from the ideal antenna connecting line.

We are trying to attain a signal of the opposite station by horizontal turning of the antenna by  $\pm 30^\circ$  from assumed direction. The vertical setting is changed gradually, and the scanning in the direction of reception is done by horizontal turning. We do not recommend changing both directions at the same time. The maximum reception is set approximately.

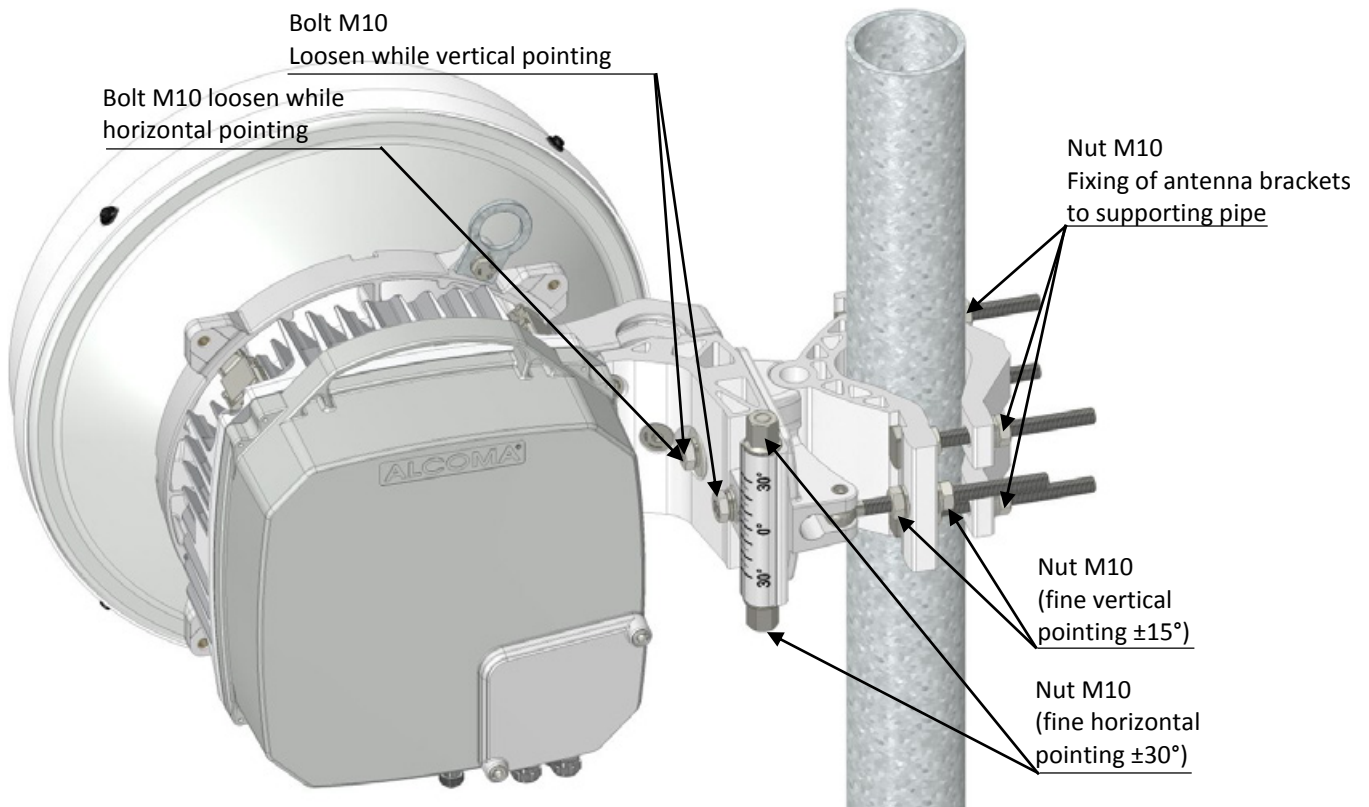

Figure 28 Pointing of AL80 GE link with UNI1-80RF (UNI2-80RF) antenna

**Fine horizontal pointing**

- Loosen M10 bolt and nut using wrench no. 17. It is better to loosen the nuts without unnecessary play that would later cause a loss of exact direction after tightening.
- While turning fine horizontal pointing nuts of you can find the main lobe on the connected DC voltmeter and in the beginning of measurement also both side lobes of the antenna radiation characteristic.
- Setting of the maximum level on the **main lobe**.
- After you set the maximum level on the main lobe, fix the antenna in the found direction by tightening the antenna support M10 bolts and nuts.
- 

**Fine vertical pointing**

- Loosen M10 bolts. It is better to loosen the nuts without unnecessary play that would later cause a loss of exact direction after tightening.
- While turning fine vertical pointing bolt of you can find the main lobe on the connected DC voltmeter and in the beginning of measurement also both side lobes of the antenna radiation
- Setting of the maximum level on the **main lobe**.
- After you set the maximum level on the main lobe, fix the antenna in the found direction by tightening the antenna M10 bolts.

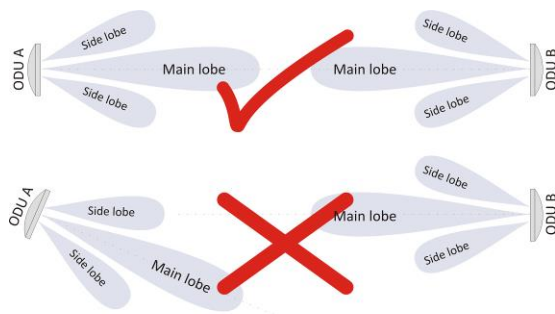

Figure 29 Pointing

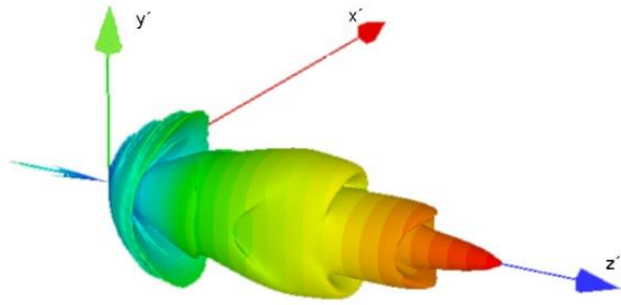

Figure 30 Radiation diagram

The pointing procedure in both horizontal and vertical directions must be repeated several times to make sure that the best maximum of the radiation characteristic was found. The opposite station antenna needs to be final adjusted the same way.

### Checking of Pointing

The value of received level can be determined by direct reading in the ASD monitoring program or by calculation using the calibration graph for RSSI. The RSSI voltage can be measured at the BNC connector without necessity to adjust the rotary switch.

To check for the proper pointing, it is good to calculate the signal level that should be measured. The maximum allowed deviation between the calculated and measured signal levels is  $\pm 3$  dB. If the negative deviation is higher the connection needs to be better pointed. Control calculation is described in chapter 4.2 on page 42.

The noise level on the receiving channel needs to be checked while the opposite station is switched off. The minimum requested separation of the noise level from the received signal is 20 dB. The opposite station can be switched off remotely using the ASD monitoring program.



- While **wrong pointing in one direction** (e.g. vertical) only **side lobes** may be found in the **second direction**.
- Pointing to side lobe is a common mistake. You may find sharp maximum, but the RX level is 13 dB lower.
- We recommend finding main lobe and both side lobes during the first pointing step.

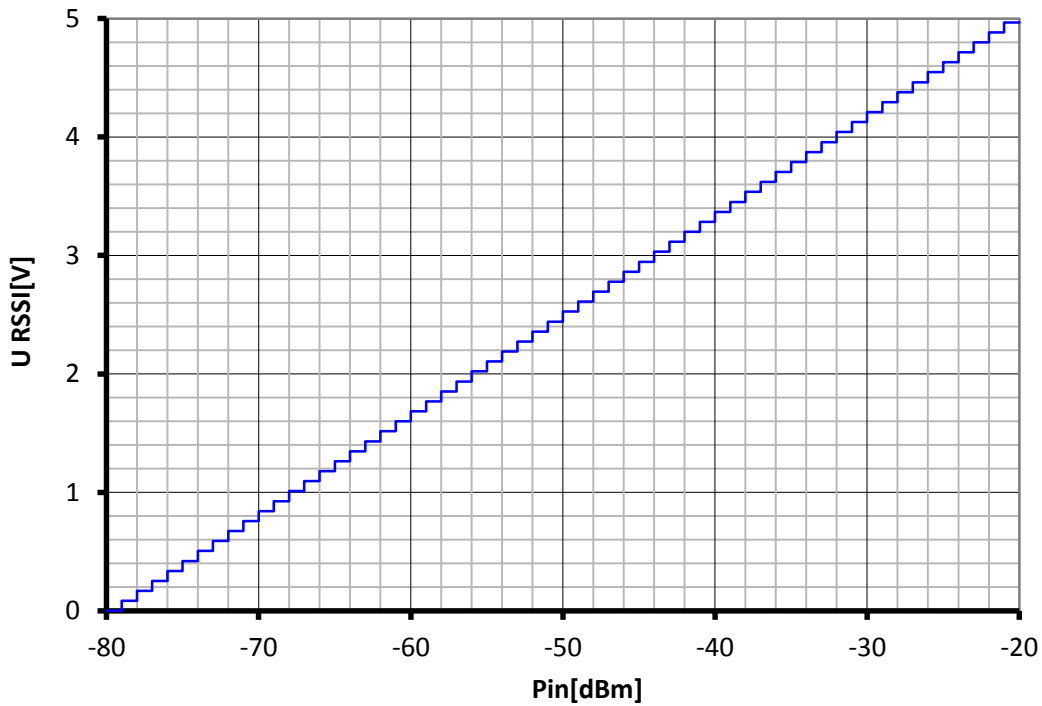

Figure 31 The RSSI calibration graph

**Change of polarization**

Polarization is changed by rotation of ODU by 90°.

- Loosen 4 latches attaching ODU to the antenna.
- Rotate ODU by 90° to the left or to the right. Grommet of interconnect cable must point down for horizontal polarization ant to the side for vertical polarization – see figure 32.
- Attach ODU to the antenna by 4 latches.
- Right hand or left hand ODU installation can be determined according to the ODU position to the supporting pipe while looking to the parabola from the front side.

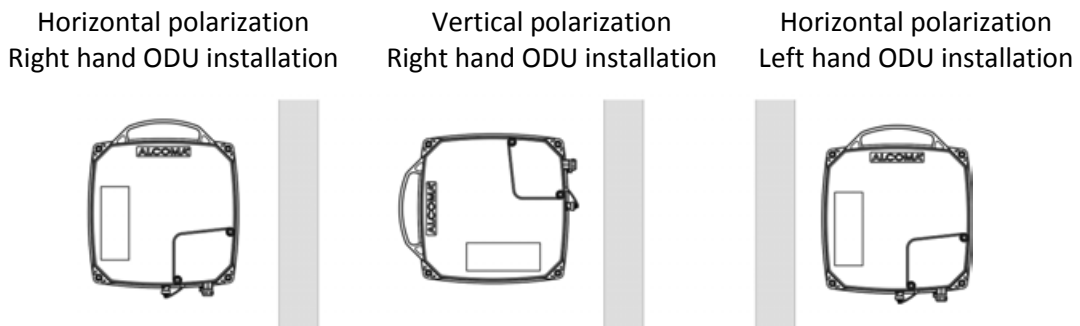

Figure 32 Setting of polarization for AL80GE

## 4.2 CONTROL CALCULATION

The following relationship is valid for the calculation of a level at the output of the receiving antenna, i.e., at the input of the microwave receiver:

$$P_{in}[dBm] = P_{vys}[dBm] + G_{antV}[dB] + G_{antP}[dB] - A_0[dB]$$

where:

|                |   |
|----------------|---|
| $P_{vys}[dBm]$ | is the transmitted output of the opposite station |
| $G_{antV}[dB]$ | is the transmitting antenna gain                  |
| $G_{antP}[dB]$ | is the receiving antenna gain                     |
| $A_0[dB]$      | is the free environment attenuation               |

The following relationship is valid for the attenuation of free environment during good climatic conditions (without rain and fog):

$$A_0[dB] = 92.44 + 20 \log( d[km] * f[GHz] )$$

where:

|          |                           |
|----------|---------------------------|
| $d[km]$  | distance between antennas |
| $f[GHz]$ | used frequency.           |

The calculated values  $P_{in}$  can be compared with the values measured by using the RSSI calibration graph, or by direct reading of the values given by the monitoring program.

If the constructed connection has a partially disturbed first Fresnel zone then the attenuation due to the disturbance cannot be higher than -6 dB in comparison with a free path. The optical visibility along the antenna axis has to be maintained in any case. In the opposite case retranslation would have to be used, and the critical spot would have to be circumvented.

The additional attenuation of the path given by the disturbance of the 1st Fresnel zone by a single terrain obstacle with a sharp peak is represented by the graph (figure 33). The graph shows the relative height of the obstacle  $z$  related to the ellipsoid radius of the 1st Fresnel zone. The value  $z = 0$  represents the edge that touches the optical connection, i.e., covering of 50% of the ellipsoid of the 1st Fresnel zone.

Additional attenuation behind an obstacle

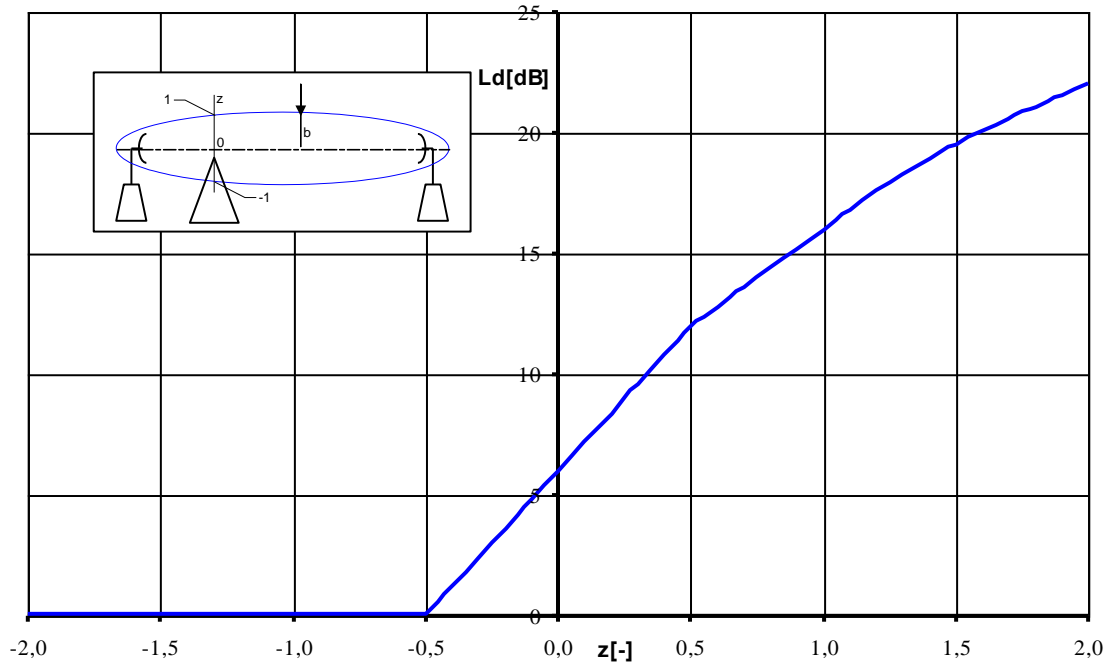
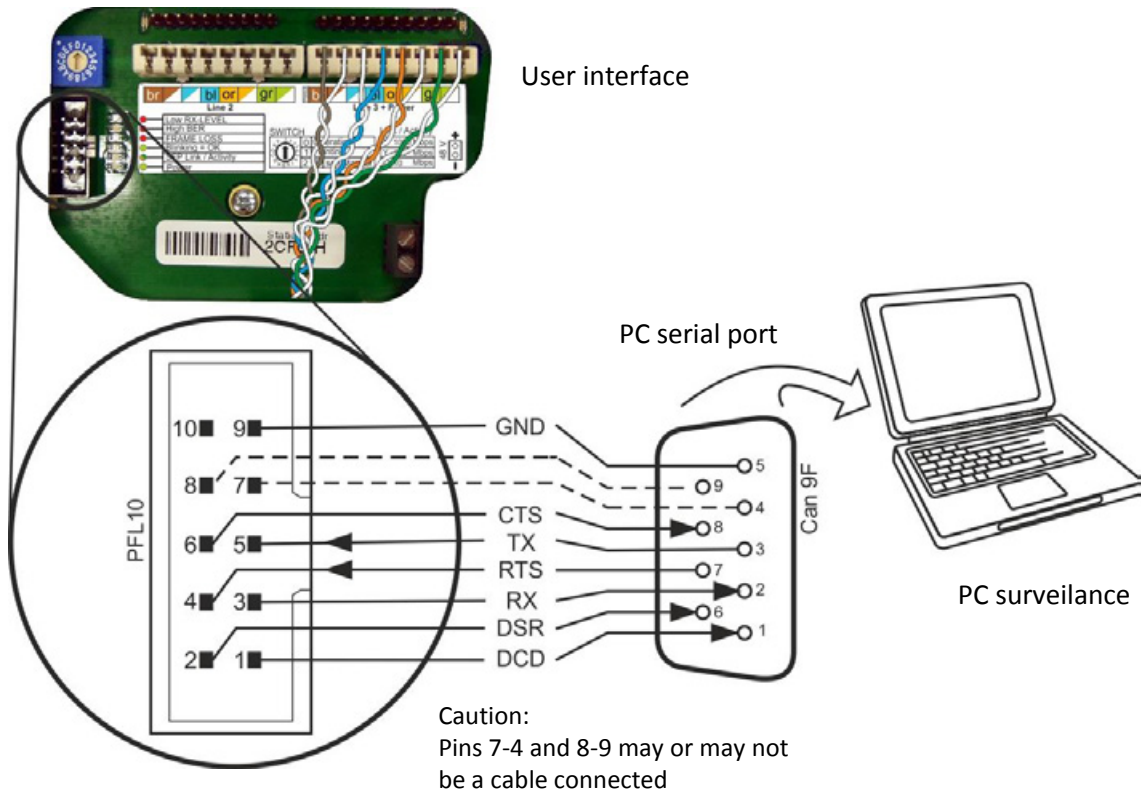

Figure 33 The approximation of additional attenuation behind an obstacle

### 4.3 DIRECT CONNECTION OF A MONITORING PC

Normally the communication of the monitoring PC with the AL80GE station takes place through data connection (TCP/IP protocol) over Ethernet, where both user data, and the monitoring data are transmitted. If this connection is not possible the monitoring PC with installed and running, ASD program can be connected directly to ODU through an RS-232 interface. The interface connector PFL10 is located on the ODU motherboard. The connector is accessible after opening of the ODU box cover. All standard signals with the RS-232 interface signal level are brought onto this connector, while the signal ground of this interface is galvanically connected with the ODU ground.

A cable connected according to the following figure can be used for this connection:



**Figure 34 The direct connection of the monitoring PC**

If the PC frame is galvanically connected with the power grid, the direct monitoring of the PC to ODU is not recommended. With regard to possible transfer of noise signals from the ODU unit to the power grid and the other way round this connection is only an emergency solution acceptable for a short time.

For service purposes ALCOMA delivers a cable ended on one side by the Cannon 9F connector and on the other by the Cannon 9M and PFL10 connectors, which connects the DCD, RX, TX, DSR, DTR, RTS, and CTS signals. The cable is intended for a temporary connection of the monitoring PC with the monitoring processor in ODU.

The minimum 4 wire connection requires the RX, RTS, TX signals and the signal grounding, i.e., using of no. 3, 4, 5, and 9 pins.

## 5. OPERATION INSTRUCTIONS

### 5.1 OPERATION

The radio relay link AL80GE does not require any service or maintenance during operation.

The radio relay link AL80GE can be remotely monitored by the ASD program that is intended for the management and diagnostics of the ALCOMA radio relay links using a monitoring PC during operation. All actual states, events and instructions are shown in individual windows in the arrangement according to separate functions or meanings (local station window, alarm history, station configuration, etc.). The monitoring system enables diagnostics of the radio links and both local and remote ends of the connection. The monitoring system is not necessary for the link transfer function itself (the link can be operated even without monitoring elements). However, monitoring is giving us diagnostic possibilities that simplify checking of the proper link function, or localization of possible defects. Detailed description and use of the ASD monitoring program is in a separate manual.

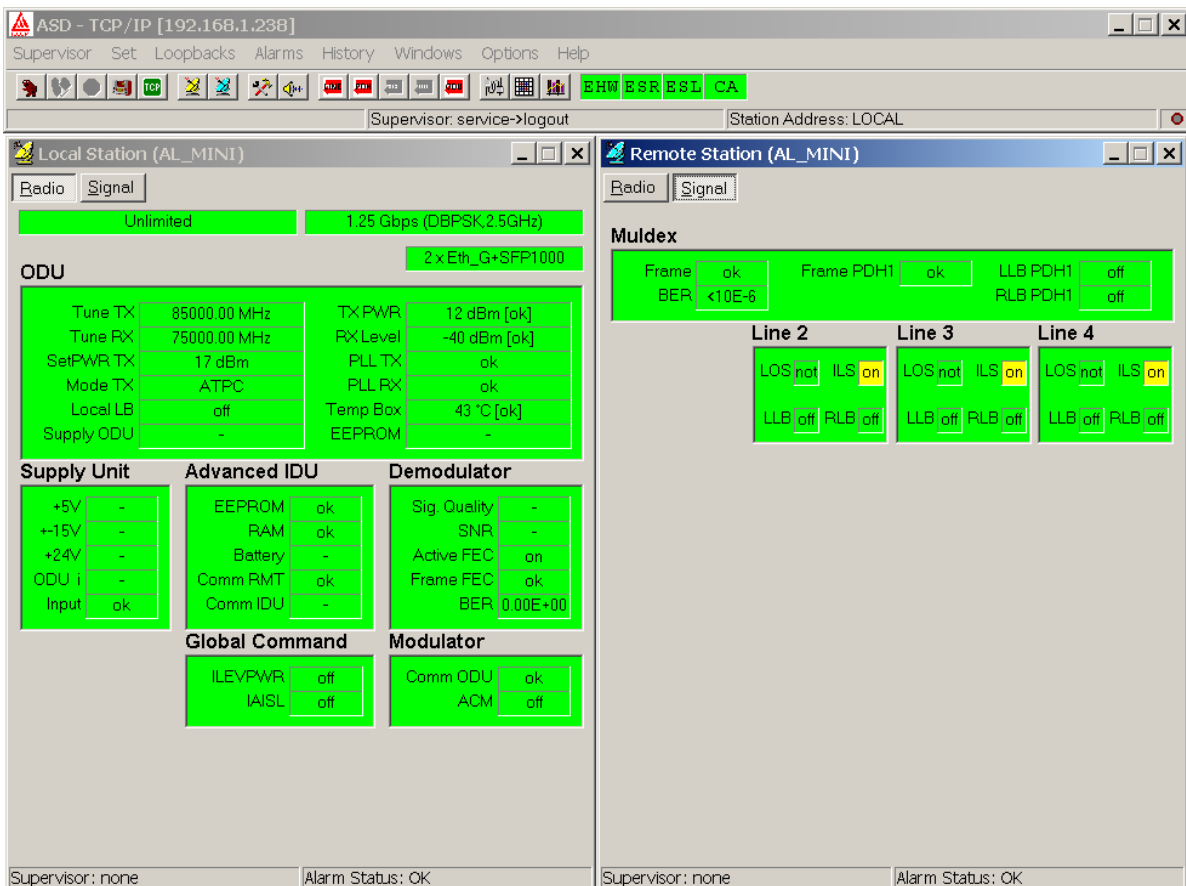

Figure 35 Main window of ASD program

According to the standards regular inspections and checks of safe status during operation are recommended once every 24 months. (see the chap. 6). Inspections and checks are recommended to be performed by the supplier professional service.

## 5.2 EMERGENCY CONDITIONS

Emergency conditions are such states and equipment demonstrations that can cause property damage and endanger health and safety of persons. These states and demonstrations include: damage of covers, connection cables, loosening of the equipment mechanical connections, strong corrosion, excessive heating, smell, smoke, etc.



### WARNING

In case that any emergency conditions are observed, the operator must immediately remove them.

## 5.3 REPAIRS



### CAUTION

Equipment repairs can be performed only by personnel that have necessary professional qualifications and have been instructed at the manufacturer according to the microwave data link AL80GE service manual. Operation personnel are prohibited from opening covers, breaking seals and unprofessionally interfering with the equipment.

After each product repair or discovery of emergency condition there must be demonstrable inspection of the safe product condition. This inspection must be recorded and signed by an authorized person. This record must be handed, together with the repaired product, to the user. The inspection may be performed by qualified personnel.

Since the current version of the AL80GE link does not support E1 transmission, it is not possible to perform any measurement loop for the purpose of error diagnostics using the ASD monitoring program.

## 5.4 ENDING OF OPERATION – ECOLOGICAL LIQUIDATION

The product is, from the ecological standpoint, classified as a hazardous electrotechnical object. After its service life it is an electronic waste, and as such it must be handed over to the appropriate enterprises that perform recycling of old electronic products. The product may not be liquidated as general community waste.

Every serial label that is placed on each product shows a graphic symbol of stricken through waste bin that cautions about obligations related to liquidation of electronic waste.



The product transport packaging is made from common recyclable material (paper and polyethylene) marked as such by a label.



## 6. SAFETY CHECK

Each AL80GE radio link is verified within check-out inspection, and its parameters are measured according to standards (Inspection and testing of electrical installations). According to standards the ODU of the radio relay link AL80GE is an electrical device used in the outside environment, supplied by SELV (Safety Extra-Low Voltage) supply and inside of the unit there is no higher voltage than SELV. The unit allows connection of dead parts by a grounding bolt to a protection circuit that serves also as a protection against overvoltage and overcurrent of atmospheric origin.

### **In agreement with the standards the ODU belongs to**

- according to its use – appliances used in outside areas
- the class III according to protection – protection against injury by electric current is based on the connection to a SELV supply, with the voltage no higher than SELV.

According to the standards regular inspections and checks of safe status during operation are recommended once every 24 months. Inspections and checks are recommended to be performed by the supplier professional service.

### **The following activities are recommended during regular checks and inspections:**

- Check of ODU tightness.
- Condition of antenna OPN (protection against icing) cover.
- Status of interconnect cable and its grommets.
- Tightening and lubrication of all attachment bolts and nuts. No construction part can be weakened or damaged by corrosion.
- Checking of grounding connection strength at grounding points and their connection to earth.
- Finding possible damage or changes of the whole system that would require further measures and the verification of safety.
- We recommend measuring and recording the level of received signal.

## 7. RADIO RELAY LINK PARAMETERS

### 7.1 FREQUENCY PLAN 80GHz

Radio relay stations ALCOMA AL80GE work in 71-76 and 81-86 GHz frequency band. Radio relay link operation in each country must be allowed by local regulations. The band is divided according to the recommendations of ECC/REC/(05)07 to channels with a width of 250 MHz. For links with the higher bandwidth channels to connect. ECC/REC recommended due to the width of the transmitted bandwidth links AL80GE use two channel pairs

| A - band lower half       |                                       |                                   | B - band upper half       |                                       |                                   |
|---------------------------|---------------------------------------|-----------------------------------|---------------------------|---------------------------------------|-----------------------------------|
| Channel number<br>ECC/REC | Recommended<br>channel pairs<br>[MHz] | Transmitter<br>frequency<br>[MHz] | Channel number<br>ECC/REC | Recommended<br>channel pairs<br>[MHz] | Transmitter<br>frequency<br>[MHz] |
| 1                         | 1<br>72 000,00                        | 71 250,00                         | 1'                        | 1'<br>82 000,00                       | 81 250,00                         |
| 2                         |                                       | 71 500,00                         | 2'                        |                                       | 81 500,00                         |
| 3                         |                                       | 71 750,00                         | 3'                        |                                       | 81 750,00                         |
| 4                         |                                       | 72 000,00                         | 4'                        |                                       | 82 000,00                         |
| 5                         |                                       | 72 250,00                         | 5'                        |                                       | 82 250,00                         |
| 6                         |                                       | 72 500,00                         | 6'                        |                                       | 82 500,00                         |
| 7                         |                                       | 72 750,00                         | 7'                        |                                       | 82 750,00                         |
| 8                         | Reserved<br>according to<br>ECC/REC   | 73 000,00                         | 8'                        | Reserved<br>according to<br>ECC/REC   | 83 000,00                         |
| 9                         |                                       | 73 250,00                         | 9'                        |                                       | 83 250,00                         |
| 10                        |                                       | 73 500,00                         | 10'                       |                                       | 83 500,00                         |
| 11                        | 2<br>74 500,00                        | 73 750,00                         | 11'                       | 2'<br>84 500,00                       | 83 750,00                         |
| 12                        |                                       | 74 000,00                         | 12'                       |                                       | 84 000,00                         |
| 13                        |                                       | 74 250,00                         | 13'                       |                                       | 84 250,00                         |
| 14                        |                                       | 74 500,00                         | 14'                       |                                       | 84 500,00                         |
| 15                        |                                       | 74 750,00                         | 15'                       |                                       | 84 750,00                         |
| 16                        |                                       | 75 000,00                         | 16'                       |                                       | 85 000,00                         |
| 17                        |                                       | 75 250,00                         | 17'                       |                                       | 85 250,00                         |
| 18                        | Reserved<br>according to<br>ECC/REC   | 75 500,00                         | 18'                       | Reserved<br>according to<br>ECC/REC   | 85 500,00                         |
| 19                        |                                       | 75 750,00                         | 19'                       |                                       | 85 750,00                         |

Table 15 Channel table AL80GE (according ECC/REC)

## 7.2 MODULATION, THRESHOLD SENSITIVITY AND TRANSFER CAPACITY OF THE LINK

The highest internal transmission capacity including service channels is **1 250 Mbit/s**.

| Total bit speed<br>[Mbit/s] | Modulation | Typical<br>Threshold sensitivity<br>for BER = $10^{-6}$ [dBm] | Width<br>of transmitted<br>spectrum in [GHz] |
|-----------------------------|------------|---|--|
| 1 150                       | DBPSK      | -63   | 1.5  |

**Table 16** Transmission speed of AL80GE

## 7.3 TECHNICAL PARAMETERS

| Parameter   | AL80GE   |
|---|--|
| Transmitter frequency   | - lower band section (/A) 71.000 ÷ 76.000 GHz<br>- upper band section (/B) 81.000 ÷ 86.000 GHz |
| Duplex spacing  | 10 GHz   |
| Frequency stability better than   | $\pm 10 \cdot 10^{-6}$   |
| Transmitted output of basic version   | 20 dBm   |
| Transmitter spectrum mask   | ETSI 301 751   |
| Typical threshold sensitivity during BER = $10^{-6}$<br>(max. values are by +3 dB higher than typical values) | -63 dBm  |
| Ethernet user interface   | 10/ 100/ 1000Base-T(X)   |
| Optional interface 1xSFP module- Line 4   | 1000BaseLX(SX)<br>1000Base-T   |
| Input connectors for Ethernet user lines  | RJ-45  |
| Interconnect cable protected terminal box - ODU<br>(recommended type S-STP Cat.7 ACOME)                       | 4 pair shielded<br>imp. 100 $\Omega$   |
| Maximum length of interconnect cable <sup>3</sup>   | for 10Base-T 200 m<br>for 100Base-TX 100 m<br>for 1000Base-T 90 m                              |
| DC supply voltage on the protected terminal box   | 36 V ÷ 72 V  |
| Supply input for U = +48 V and 100 m connection cable   | < 40 W   |

**Table 17** Parameters of AL80GE link

<sup>3</sup> Including cable between terminal box and the first active equipment.

| Parameter   | Value              |
|---|--------------------|
| Dimension of 3 joined terminal boxes ALS1x (w x h x d)            | 482 x 44 x 138 mm  |
| ALS1x terminal box dimensions (w x h x d)                         | 162 x 44 x 135 mm  |
| ODU dimensions (without antenna radiator and antenna) (w x h x d) | 255 x 309 x 175 mm |
| ODU weight (without antenna and antenna radiator)                 | 6.5 kg             |
| <b>Standards</b>  |                    |
|   | EN 60950           |
|   | ETSI EN 302 217-3  |
|   | EN 301 751         |
|   | ECC Rec. (05)07    |

**Table 18 Technical parameters**

## 7.4 ENVIRONMENT

### Operation

ALSx and ODU units surrounding environment must not contain aggressive vapors and gases, must have a normal radiation level, and be without vibrations and shocks. All ALSx and ODU units are air-cooled by natural air circulation. They do not contain fans that would suck in dirt from surrounding areas and thus lower the reliability of the microwave link.

The radio link is resistant against effects of wind with speeds of up to 33 m/s (120 km/h) without influence to transmission quality. Reversible changes, i.e., elastic deformation occur up to the wind speed of 56 m/s (200 km/h). Permanent deformation can occur above this threshold, however, without damage to ODU itself.

The protected terminal box is intended for stationary use in locations protected against climatic conditions.

| Climatic Resistance   | Surrounding temperature |                       |
|-----------------------|-------------------------|-----------------------|
| Operation capability  | ALSx                    | from -25 °C to +55 °C |
|                       | ODU                     | from -35 °C to +55 °C |
| Guaranteed parameters | ALSx                    | from -25 °C to +55 °C |
|                       | ODU                     | from -33 °C to +50 °C |
| Storage ability       | ALSx and ODU            | from -25 °C to +55 °C |

**Table 19 Operational temperature**

By operation ability we understand that the radio link can be operated within the specified temperatures, but some parameters can deviate from specified limits. There will be no irreversible or permanent change or damage to units in the specified temperature range.

### Transport and Storage

The radio relay link units can be transported only in covered vehicles and the units must be protected against direct weather influence at the same time. They should be transported in suitable (best in original) packaging in order to prevent excessive loads through shaking, vibrations etc., they are not allowed to be dropped. A specific form of transport is a matter of agreement between the manufacturer and the client.

The radio relay units must be stored in dry, partially air-conditioned areas. The range of storage temperatures is  $-25 \div +55$  °C, with the relative humidity max. 85 %.

**CAUTION**

Be aware of air humidity condensation.

Condensation of air humidity inside the link may occur when moving the unit from cold to hot places. It is forbidden to switch on the equipment until those parts are not dried.

## 7.5 ANTENNA SYSTEMS

Parabolic antennas for fixed connection to ODU were developed for the 80 GHz band. The ALCOMA parabolic antennas can be used for horizontal and vertical polarization and left or right hand installation without modifications. All antennas are standard equipped by frost protection. The change of polarization is performed by turning ODU by 90°.

| Compact microwave antennas                  | Type      |           |
|---|-----------|-----------|
|   | UNI1-80RF | UNI2-80RF |
| Parabola diameter                           | Ø 0.35 m  | Ø 0.65 m  |
| Antenna gain $G_{ant}$ (71.0 GHz)           | 44.8 dBi  | 50.2 dBi  |
| Antenna gain $G_{ant}$ (86.0 GHz)           | 46.0 dBi  | 51.3 dBi  |
| Main lobe 3 dB                              | 0.9°      | 0,5°      |
| Fine horizontal adjustment                  | ±20°      | ±20°      |
| Fine vertical adjustment                    | ±20°      | ±20°      |
| Weight of compact antennas                  | 6.8 kg    | 9.1 kg    |
| Diameter of installation stand <sup>4</sup> | min.      | Ø 42 mm   |
|   | max.      | Ø 115 mm  |

**Table 20 80GHz antenna parameters**

**CAUTION**

Use tough constructions for installation of antenna systems. Construction should enable stable pointing even under bad weather conditions. The main lobe of antenna radiation diagram is **0.9°** for 0.35 m antenna and **0.4°** for 0.65 m antenna.

Radiation patterns are in measuring protocols for certification of ALCOMA antennas. Those may be supplied when required.

<sup>4</sup> Supporting pipe lengths must guarantee sufficient rigidity considering climatic influences of surrounding environment.

<sup>5</sup> Diameter 42 – 48 mm can be used when the wind speed does not exceed 50 m/s (180 km/h)

## 8. MAIN EQUIPMENT DIMENSIONS

### 8.1 ODU – OUTDOOR UNIT

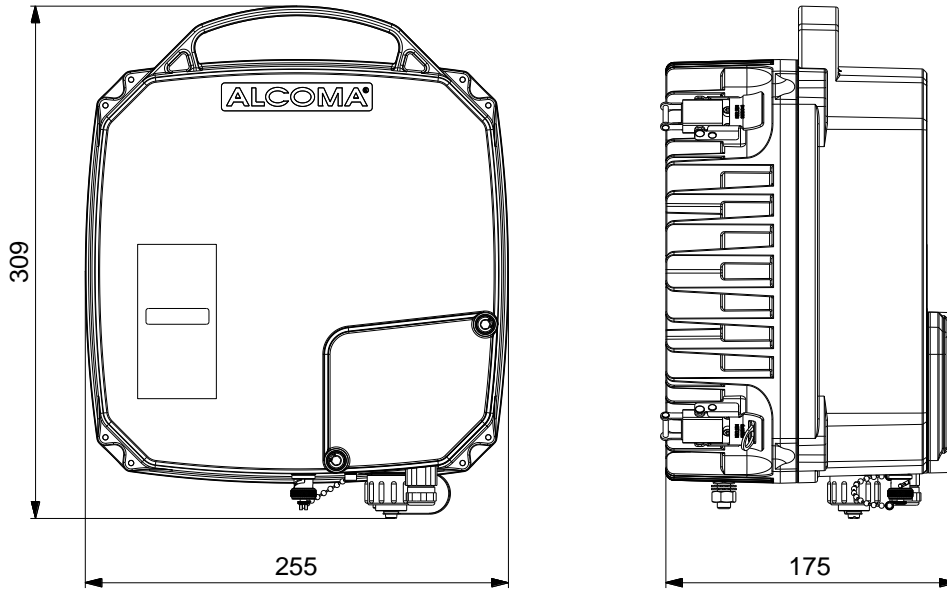

Figure 36 Main ODU dimensions

### 8.2 PROTECTED TERMINAL BOX

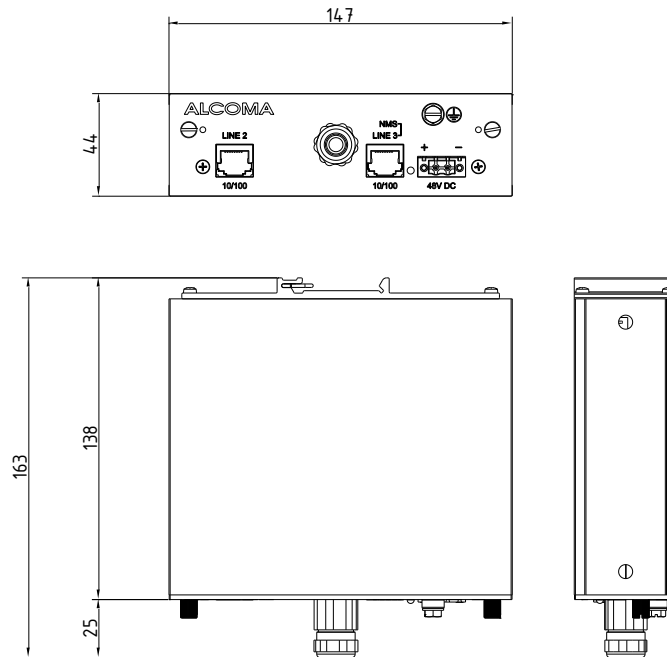

Figure 37 Main dimensions of ALS1x

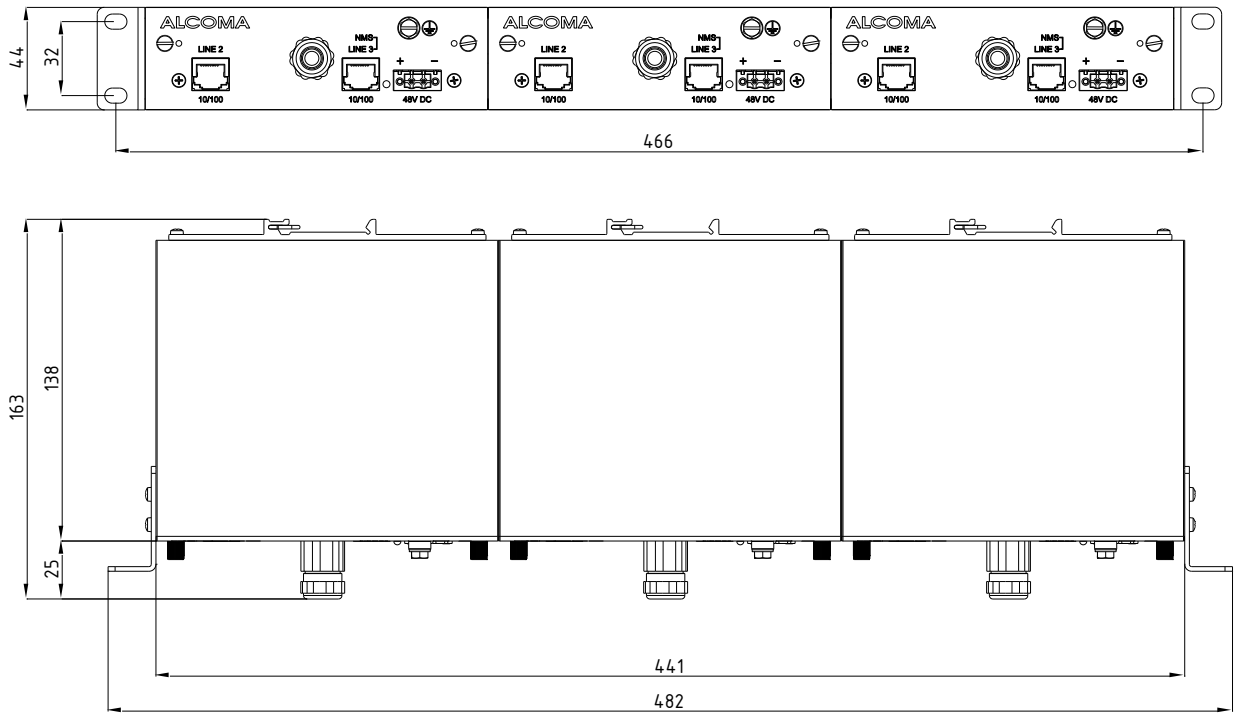

Figure 38 Main dimensions of 3 assembled terminal boxes ALS1x to 19" rack

### 8.3 ODU WITH ANTENNA

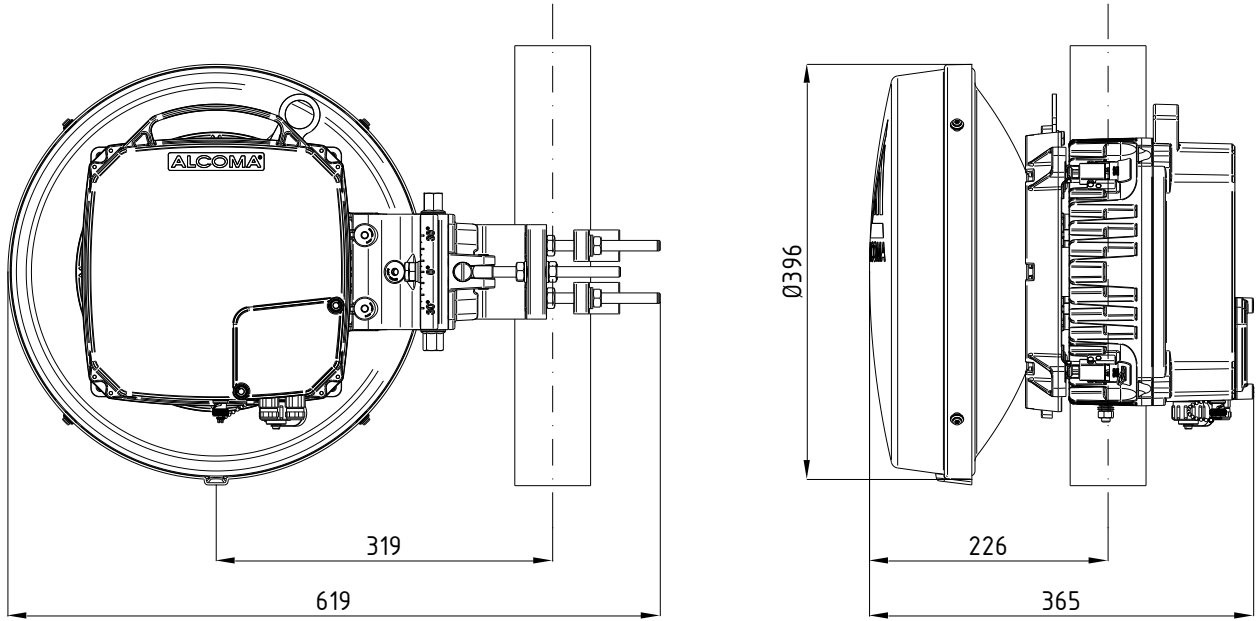

Figure 39 Main dimensions of station with UNI1-80RF antenna

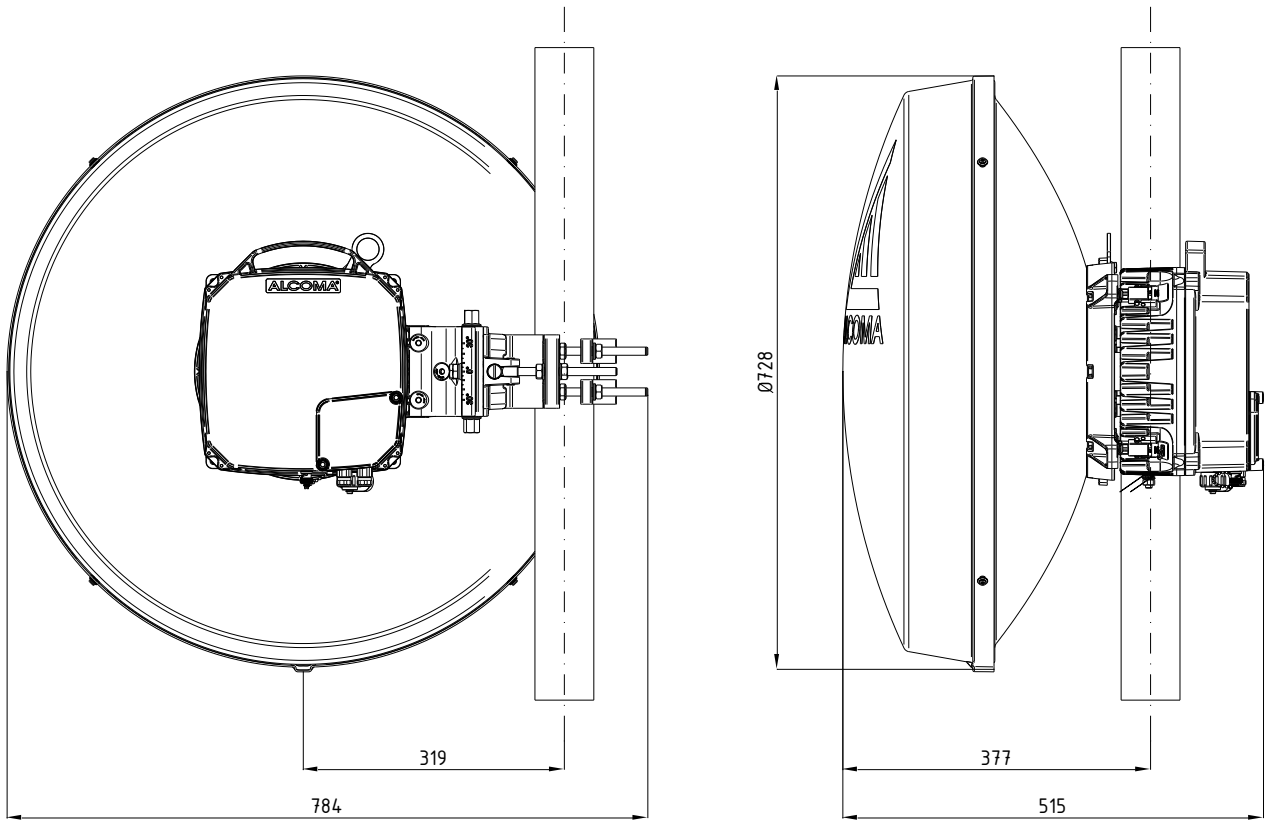

Figure 40 Main dimensions of station with UNI2-80RF antenna

## 9. APPENDIXES

### 9.1 LIST OF FIGURES

|  |    |
|--|----|
| The block schematic of the AL80GE link .....   | 6  |
| Assembling the three ALS1x to 19" 1U unit.....   | 8  |
| Protected terminal box ALS1-GEth Line 3.....   | 9  |
| Protected terminal box ALS1-GEth .....   | 9  |
| Protected terminal box ALS1-GEth RP .....  | 9  |
| Protected terminal box ALS1-GEth RP .....  | 9  |
| Protected terminal box ALS1-GEth + Line 2 NMS .....  | 9  |
| Cable wiring in ALS1-GEth and ALS1-2GEth boxes .....                                       | 13 |
| Separate management - wiring in the terminal box.....                                      | 13 |
| The ODU connection places.....   | 14 |
| User space ODU 1xGEth.....   | 17 |
| User space ODU 2xGEth.....   | 18 |
| The ODU user space 1xGEth separate management.....   | 18 |
| The Fresnel zone .....   | 21 |
| Improper placement of antenna on mounting pipe .....                                       | 21 |
| Proper placement of antenna on mounting pipe .....   | 22 |
| The examples of channel and polarization usage in case of more links in one location ..... | 23 |
| ODU attachment to UNI1-80RF (UNI2-80RF) antenna .....                                      | 24 |
| Attachment of UNI1-80RF (UNI2-80RF) antenna holder .....                                   | 25 |
| The terminal grounding .....   | 26 |
| Attachment of feeder to the UNI1-80RF (UNI2-80RF) antenna .....                            | 27 |
| Typical ODU wiring .....   | 28 |
| Manipulation with the user space cover .....   | 29 |
| The grommet installation .....   | 31 |
| Finished assembly of the connection cable Cat7 S-STP .....                                 | 31 |
| Optional SFP modules.....  | 32 |
| Connection of the connecting cable .....   | 35 |
| Pointing of AL80 GE link with UNI1-80RF (UNI2-80RF) antenna .....                          | 39 |
| Pointing.....  | 40 |
| Radiation diagram.....   | 40 |
| The RSSI calibration graph .....   | 41 |
| Setting of polarization for AL80GE.....  | 41 |
| The approximation of additional attenuation behind an obstacle .....                       | 43 |
| The direct connection of the monitoring PC.....  | 44 |
| Main window of ASD program.....  | 45 |
| Main ODU dimensions .....  | 52 |
| Main dimensions of ALS1x.....  | 52 |
| Main dimensions of 3 assembled terminal boxes ALS1x to 19" rack .....                      | 53 |
| Main dimensions of station with UNI1-80RF antenna.....                                     | 54 |
| Main dimensions of station with UNI2-80RF antenna.....                                     | 54 |

## 9.2 LIST OF TABLES

|  |    |
|--|----|
| RJ45 connector wiring – user lines Line 2 a Line 3.....                                    | 10 |
| The protected terminal box - cutting box “KRUNE” for the Line 2.....                       | 11 |
| Separate management – The protected terminal box – cutting box “KRUNE” for the Line 2..... | 11 |
| The protected terminal box - cutting box “KRUNE” for the Line 3 + power.....               | 12 |
| The outdoor unit - cutting box “KRUNE” for the Line 2.....                                 | 15 |
| Separate management – The outdoor unit – cutting box “KRUNE” for the Line 2.....           | 15 |
| The outdoor unit - cutting box “KRUNE” for the Line 3 + power.....                         | 16 |
| Connector for direct connection of power supply.....                                       | 16 |
| Connector PFL10 for direct connection of PC.....   | 17 |
| Meaning of LEDs in the ODU user space.....   | 19 |
| Meaning of LEDs next the cutting box “KRUNE” in the ODU user space.....                    | 19 |
| Description of functions of the rotary switch in the ODU user space.....                   | 19 |
| Recommended antenna placements considering a distance from an obstacle.....                | 22 |
| Max. TX power values depending on antennas and distance.....                               | 37 |
| Channel table AL80GE (according ECC/REC).....  | 48 |
| Transmission speed of AL80GE.....  | 49 |
| Parameters of AL80GE link.....   | 49 |
| Technical parameters.....  | 50 |
| Operational temperature.....   | 50 |
| 80GHz antenna parameters.....  | 51 |

ALCOMA a.s. | Vinšova 11 | 106 00 Prague 10 | Czech Republic  
E-mail: [alcoma@alcoma.cz](mailto:alcoma@alcoma.cz)  
[www.alcoma.com](http://www.alcoma.com)