



Microwave antenna UNI1-13

Antenna description

High Performance \varnothing 0.35 m antenna for ALCOMA point to point radiorelay links with standard holder or AFM holder for precise alignment.

General parameters

Diameter	0.35 m (1 ft.)
Feeder	single polarized (dual polarized)
Polarization	horizontal / vertical (dual)
Input flange: - standard - optional	circular, hole diameter 16.00 mm R120 (WR75)
Environmental temperature	-35 °C to +55 °C
Color	light grey
Radom material	white plastic (ABS + PMMA)



Electrical parameters

Frequency band	12.700 - 13.250 GHz
Gain: - low band	29.9 dBi
- mid band	30.1 dBi
- high band	30.3 dBi
Beamwidth (-3 dB)	4.5° (H / V)
Return loss	< 1.30 (17.7 dB)
Front to Back Ratio	55 dB
Cross Polarization Discrimination	30 dB
Antenna class	2 or 3 (ETSI EN 302 217-4-2)

UNI1-13-AF

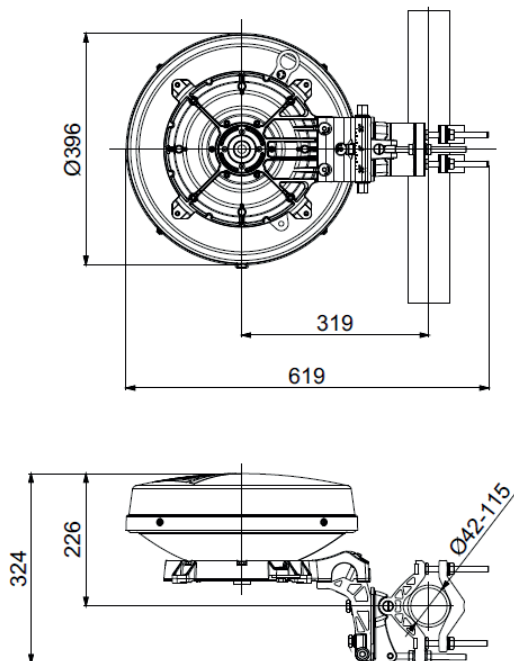

UNI1-13-AS

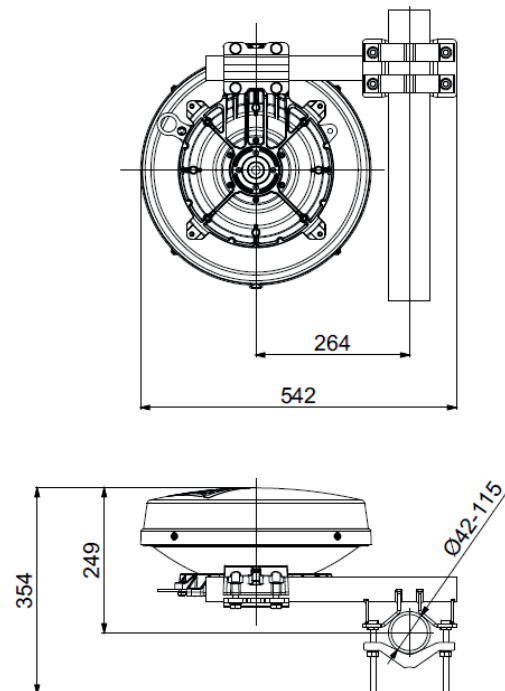



Microwave antenna UNI1-13

Mechanical parameters due to wind UNI1-13-AF

UNI1-13-AS

Performance stability	max 30 m/s (110 km/h)	max 30 m/s (110 km/h)
Survival	max 55 m/s (200 km/h)	max 55 m/s (200 km/h)
Radial ice load (density 7kN/m ³)	25 mm	25 mm
Net weight (interface A/R)	6.5 kg / 6.8 kg	6.7 kg / 7.0 kg
Pipe diameter*	42 - 115 mm	42 - 115 mm
Adjust azimuth / elevation		±180° / ±20°
Fine adjust azimuth	±15°	—
Fine adjust elevation	±30°	—

Force and twisting moment due to wind

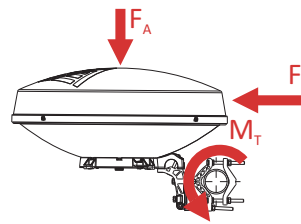

Wind velocity	30 m/s	55 m/s	30 m/s	55 m/s
F_A - axial force	100 N	325 N	100 N	325 N
F_S - side force	35 N	105 N	35 N	105 N
M_T - twisting moment	35 Nm	105 Nm	30 Nm	90 Nm
Icing thickness 25 mm	18 kg			

* diameter 42 - 48 mm can be used when the wind speed does not exceed 50 m/s (180 km/h)